

NOTE:

- 1 SHIELD ON CONNECTOR END TO BE TRIMMED FLUSH WITH CABLE JACKET (N/C)
- 2 ALL SOLDERING TO BE PER GOOD COMMERCIAL PRACTICE

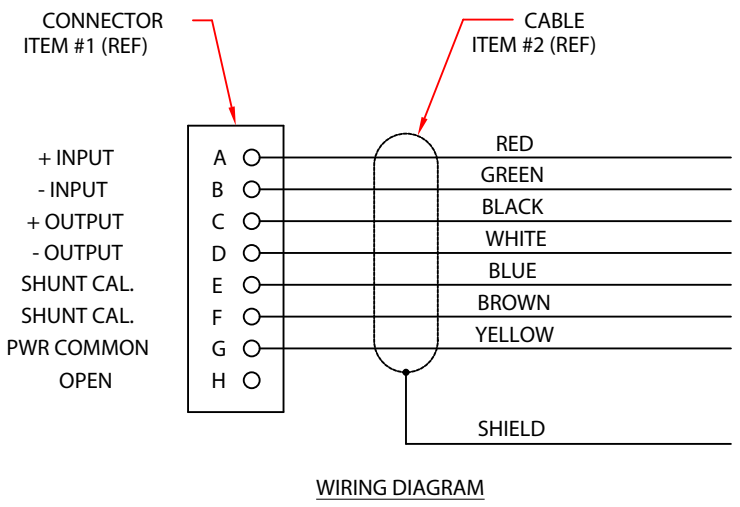
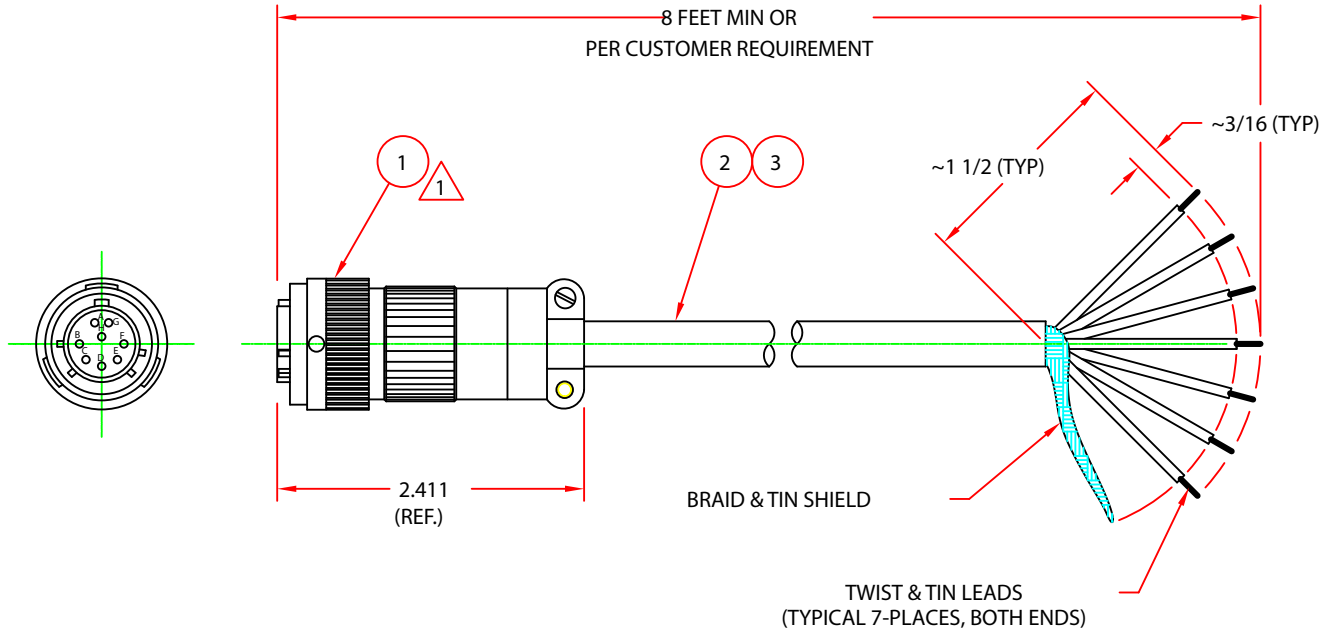

NEXT ASSEMBLY		REFERENCE DRAWING	
FINAL		FR0015	
AR	1300060/40	SOLDER	
8.5'	1220075003	CABLE, BELDEN #8427	
1	10MSPT12J8	CONNECTOR, ARRAY #PW06JF12-085	
QTY.	PART NO.	DESCRIPTION	ITEM

UNLESS OTHERWISE SPECIFIED DIMENSIONS ARE IN INCHES

TOLERANCES ON FRACTIONS ±1/64
 DECIMALS-
 .XX ±.01
 .XXX ±.005
 ANGLES ±1/2°

63 MACHINE FINISH (ALL SURFACES)
 REMOVE BURRS & BREAK SHARP EDGES
 .015 MAX.
 MACHINE FILLETS TO .015 R. MAX.
 ALL DIAMETERS TO BE CONCENTRIC
 WITHIN .010 F.I.M.
 CHAMFER ALL MALE THREADS 45°±5°
 TO MINOR DIAMETER
 C'SINK ALL FEMALE THREADS 90°±10°
 TO MAJOR DIAMETER

REVISIONS			
LET	DATE	BY	ECN
-	7/8/99	MC	8165
A	1/3/00	LP	8346

**MATING CABLE ASS'Y,
 MODELS 2XX-15 WITH 'BA' CONNECTOR**

SCALE	1/1	MATERIAL	SEE B/M	DRAFTSMAN	DATE
ENGINEER	DATE	REVIEW	DATE	M.CECERE	7/8/99
APPROVED				DATE	VENIKOV 7/13/99

DRAWING NO. **230439**

Viatran
 CORPORATION
 WHEATFIELD, NEW YORK USA

