

Viatran 386 Flush Tip Sensor for industrial applications including paint finishing systems and process pressure measurements.

- Special design minimizes torque effect on the diaphragm, which eliminates the need to make adjustments to the instrument after installation.
- Optically isolated shunt calibration circuit to quickly check electronics operation (Optional)
- Designed with rugged stainless steel diaphragm, minimizes wear on sensor which improves quality of data being collected.
- Fully sealed housing prevents fluid ingress (which damages electronics) and extends life of unit.
- Flush sensor prevents clogging, less down time for cleaning.



PERFORMANCE

Standard Pressure Ranges.....	0-100,150,160, 200, 300, 500, 750, 1000, 1500, 2000, 3000, 5000, (0-100 thru 0-10,000 PSIG, PSIS)	7500, 10,000 PSIG, PSIS
Static Error Band.....	$\leq \pm 0.5\%$ FSO (Includes BFSL, Hysteresis and Repeatability by RSS)	
Compensated Temperature Range	70°F to 170°F (21°C to 77°C)	
Operating Temperature Range.....	-40°F to 185°F (-40°C to 85°C)	
Storage Temperature Range.....	-40°F to 250°F (-40°C to 120°C)	
Long Term Stability (%FSO)	$\leq \pm 0.25\%$ FSO per 6 months	
Thermal Effect on Zero	$\leq \pm 2\%$ FSO per 100°F Typical	
Thermal Effect on Span	$\leq \pm 2\%$ FSO per 100°F Typical	

ELECTRICAL

Output Signal	4-20 mA	
Supply Voltage	8-28 Vdc	
Power Supply Regulation	$< \pm 0.05\%$ FSO per volt	
Load Impedance.....	926 Ohms maximum at 28 volts DC	
Circuit Protection.....	Reverse polarity protected, CE marked	
RFI/EMI.....	CE EMC compliant as per IEC EN 61326-1 and EN 61326-2-3 Annex BB	
Voltage Spike Protection	Withstand 1,000 volt spike per EN 61000-4-5	
Insulation Resistance.....	< 5 nS	
Response Time.....	< 2 mSec for 10-90% of final value	

MECHANICAL

Standard Pressure Port.....	1/2" NPT (M)	
Zero Effect from Installation	$< \pm 0.10\%$ at 25 to 50 ft lbs	
Proof Pressure	1.5x	
Burst Pressure	5x (or 30,000 PSI, whichever is less)	

MATERIALS OF CONSTRUCTION

Wetted Materials	15-5PH and 304L Stainless Steel (Inconel 718 optional)	
Weight.....	8 oz. nominal	

Model 386 FLUSH TIP PRESSURE TRANSMITTER

HOW TO ORDER

MODEL	PRESSURE RANGE	FORMAT	ELECTRICAL CONNECTION	PRESSURE CONNECTION	OPTIONS
386	AR	S	BH	*	

Pressure Range

AM	0-100 psi	AY	0-1,000 psi
AN	0-150 psi	AZ	0-1,500 psi
CA	0-160 psi	BA	0-2,000 psi
AP	0-200 psi	BC	0-3,000 psi
AR	0-300 psi	BF	0-5,000 psi
AU	0-500 psi	BH	0-7,500 psi
AW	0-750 psi	BM	0-10,000 psi

Format

S	Sealed
G	Contact factory for gage unit

Electrical Connection

BH	Welded - 6 Pin bayonet shell size 10
ZE	Welded - 4 Pin Hermetic, shell size 14S, (MIL-DTL-5015H)
ZU	Welded - Direct Coupled Cable

Pressure Connection

*	Standard 1/2" NPT (M)
VQ	3/4"-16 UNF (M) (Includes Std Nitrile / NBR "O" ring)
VR	G 1/2" (M) (Includes Std Nitrile / NBR ED Seal according to DIN 3869)

Options

DA	Isolated Internal Shunt Cal at 80% Full Scale
DC	Extended Compensated Temperature Range (Cold) -40°F to 170°F (-40°C to 77°C)
DG	Improved Temperature Compensation to ± 1% FSO shift per 100°F
DH	Special Range
DN	Improved Non-linearity
EA	Special Calibration Run
FA	Russian Metrology Certificate
EH	Extended Compensated Temperature Range (Hot) +70°F to 185°F (21°C to 85°C)
GA	"O" Ring or ED Seal- VITON® / FKM material
GD	"O" Ring- EPDM material (not available with "VR" option)
NH	Customer Specified Identification
PW	1/8 DIN Digital Indicator
QK	Inconel 718 - for all wetted parts (minimum range is 0-150 psi)

Information is accurate to the best of Viatran's knowledge. We reserve the right to change specifications at any time. Please contact Viatran for specific order inquiries.

98DS386 Rev G



VIATRAN

Model 386 FLUSH TIP PRESSURE TRANSMITTER

Connection Diagrams & Wiring

The standard wiring of your Viatran pressure transmitter is outlined below. If your unit was ordered with an alternate connector or special wiring refer to the wiring information permanently marked on your unit.

The 386 transmitter can be powered by a DC power supply ranging from 8 to 28 volts. With a 4-20 mA device please refer to the load/voltage chart (right) to identify the required input voltage for your specific system load

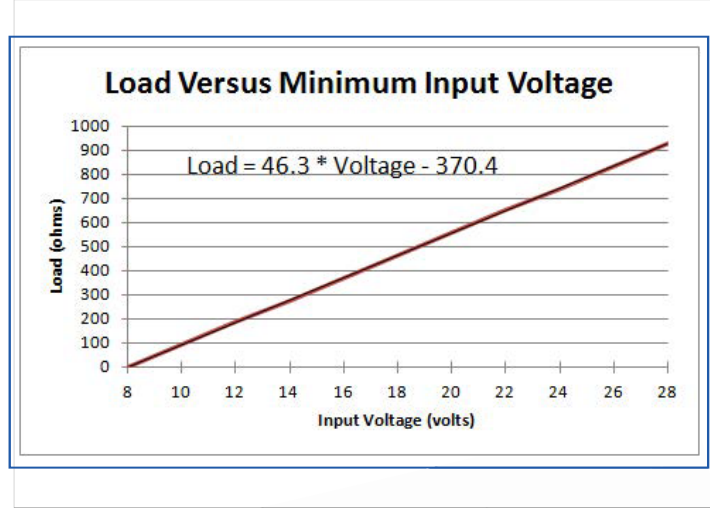

CONNECTION DIAGRAMS & WIRING

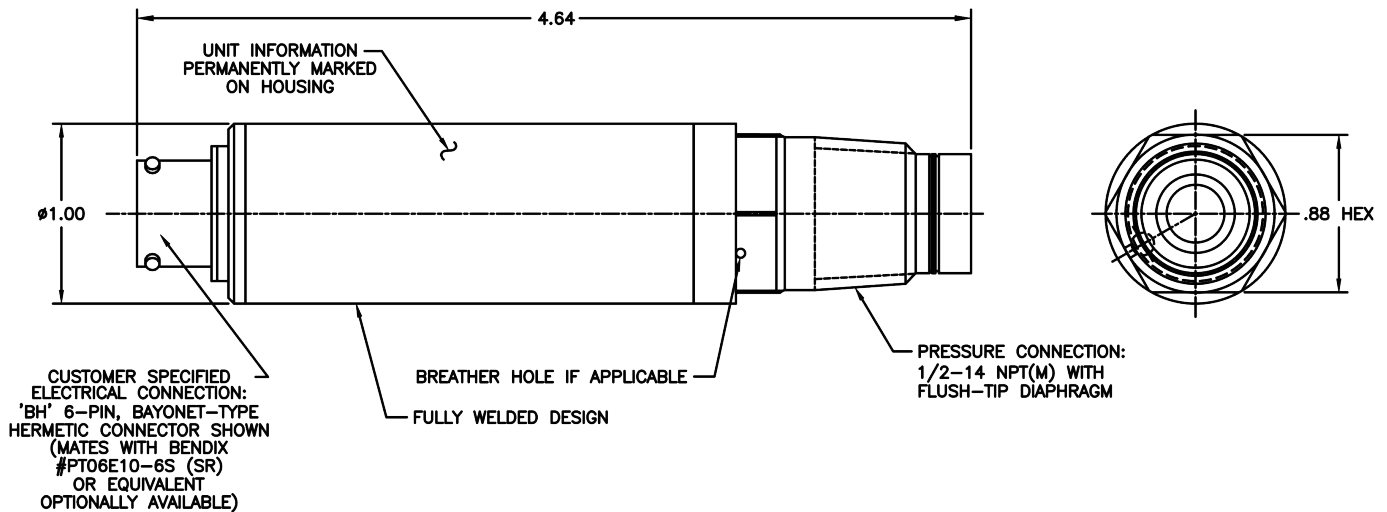
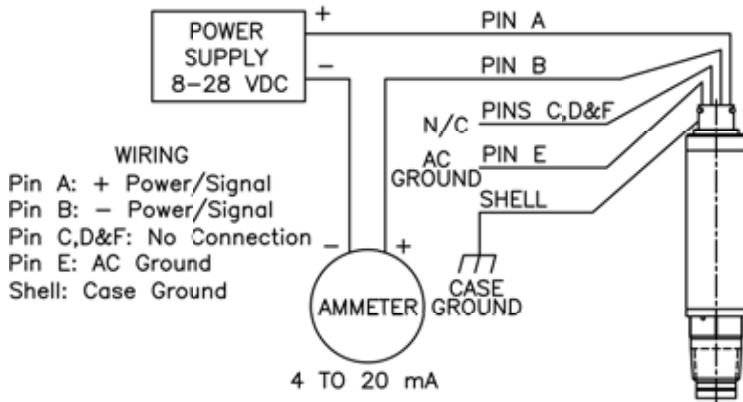

Information is accurate to the best of Viatran's knowledge. We reserve the right to change specifications at any time. Please contact Viatran for specific order inquiries.