

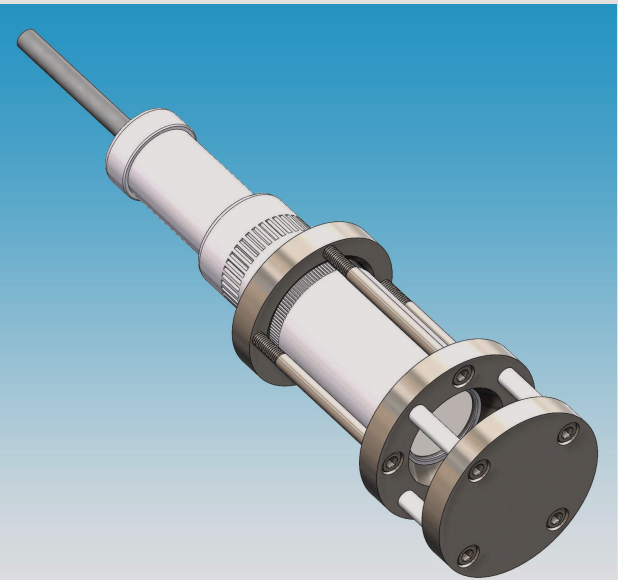

MODELS 593 / 595 / 596

OPTION DV- SHARKCAGE™



The new Viatran *SharkCage™* option is ideal for those applications where you need extra protection. *SharkCage™* is designed for use with the DLT™ Model 593 and 596 Detachable Level Transmitter (316 Stainless Steel body) or the DLT™ Model 595 (PVC body).

These models feature rugged Ceramic Sensors that will not rupture, leak or tear. Easy to remove and replace, the *SharkCage™* allows quick change of the DLT Sensor Heads whenever replacement is required.

The PUR cable's integral Kevlar cord provides 220 pounds of tensile strength which stands up well to the harsh conditions encountered. If needed, additional weighted versions are available to firmly anchor the level transmitter.

The base plate acts like a stand-off and keeps the sensor approximately 2 inches off the pit floor. Longer or taller stand-offs are available in various lengths up to 10 feet.

For assistance in selecting the best solution, contact a Viatran Applications Engineer at 1.800.688.0030 or via Email: solutions@viatran.com and ask about our "DV" options.

SHARKCAGE™ - Option DV
for Models 593, 595 & 596

Features

- Non-clogging
- Protects sensor
- Removable & Replaceable
- Stand-off Options
- Additional Weight Options

Applications

- Wastewater
- Sludge
- Slurries
- Lift Stations

800.688.0030

www.viatran.com

For Factory Installation use Option Code "DV"

For Model 593 Field Installation use P/N 005885.012

For Model 595 Field Installation use P/N 005885.032

For Model 596 Field Installation use P/N 005885.052

COMPONENTS*

1	DLT Sensor (Model 593, 595 or 596)
2	Upper Clamping Plate (Model Specific)
3	Clamping Screws (4x)
4	Lower Clamping Plate (Model Specific)
5	Stand-off Spacer & Screws (4x)
6	Base Plate

*The *SharkCage™* is sold as complete kit
(Individual components are not available separately)

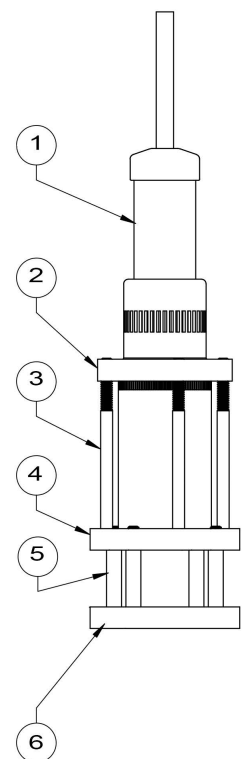

MODELS 593 / 595 / 596 OPTION DV- SHARKCAGE™

DIMENSIONAL DATA

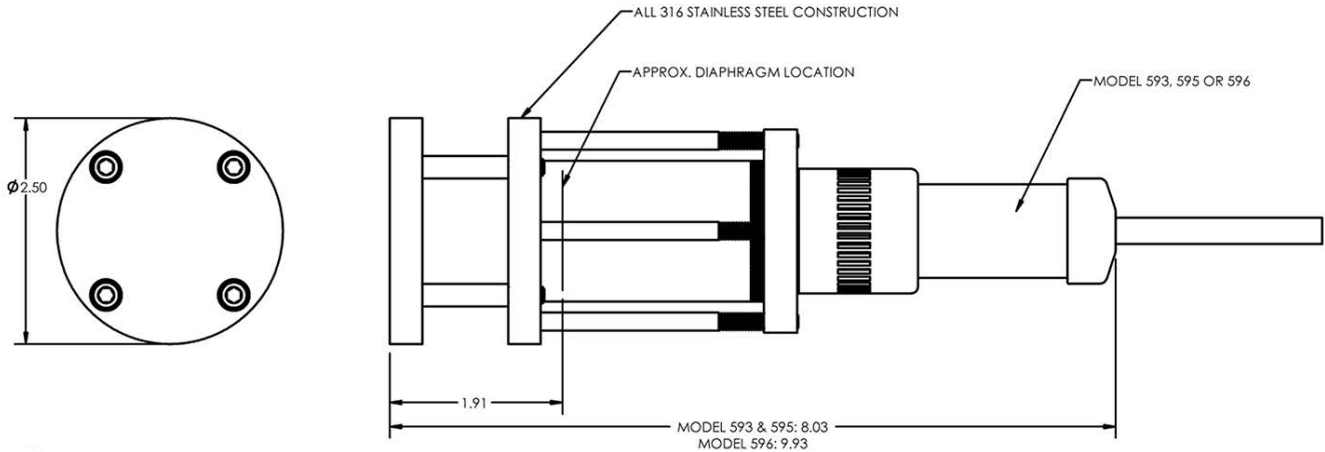

CUSTOM OPTIONS*



6 INCH STAND-OFF AND WEIGHT

*Consult a Viatran Applications Engineer for details.



199 Fire Tower Drive, Tonawanda, New York 14150 USA
International: 1-716-629-3800 | Toll Free: 1-800-688-0030
Fax: 1-716-693-9162 | Email: solutions@viatran.com
Web: www.viatran.com

An ISO 9001:2008 Certified Company
98DSDVc