



SOFTWARE MANUAL

Model 511/521/522 Pressure Transmitter



3829 Forest Parkway, Suite 500
Wheatfield, NY 14120
Toll Free: 1-800-688-0030
International: 1-716-629-3800
Fax: 716-693-9162
www.viatran.com
solutions@viatran.com

Table of Contents

SOFTWARE MANUAL	1
Software Installation and Set-up.....	4
Hardware Set-up.....	5
Hardware Set-up using the optional PowerXpress module.....	7
Navigating the Software	9
New Device.....	9
Views.....	10
Initial Screen	11
How to read the Pop-Up Screens.....	12
The “Time On” and “Read Peaks” Screens.....	12
Trim Procedure.....	13
Zero Adjust	14
Span Adjust.....	14
Restore Factory Settings.....	16
Device	17
User Information.....	17
Peaks	18
Device Information	18
HART Output.....	18
Revision #'s	18
Questions/Help.....	19

Table of Figures

Figure 1 Initial Download Screen	4
Figure 2 Activation Screen.....	5
Figure 3 Hart setup for communicating with 511/521/522 Pressure Transmitter	6
Figure 4 Example of a set up using the PowerXpress	7
Figure 5 Basic Menu	8
Figure 6 New Device	9

Users Manual for Viatran 511/521/522 Software

Figure 7 Initial Screen – [Viatran View].....	10
Figure 8 Initial Screen.....	11
Figure 9 Time On pop up screen	12
Figure 10 Read Peaks Screen	13
Figure 11 Trim Screen.....	13
Figure 12 Trim Implemented	14
Figure 13 Span Implemented	15
Figure 14 Restore All Factory Settings.....	16
Figure 15 Device User Information	17
Figure 16 User Information with edit	18

Software Installation and Set-up

The DevCom2000-LT HART software can be used to trim, read data from and store data to the Viatran 511/521/522 Pressure Transmitter. This software can only be installed and activated on one computer. If you need to transfer it to another computer, see the DevCom2000-LT User's Manual that will be downloaded when you install the software.

Follow the steps to download and install the DevCom2000-LT HART software:

1. Open the link in the email that you received from Viatran, or click on the following link and input the license and password you received from Viatran when you ordered your DevCom2000-LT HART software:

<https://procomsol.com/download/DevCom2000LiteSetup-Viatran.zip>

2. Unzip the files and run "DevCom2000LiteSetup.exe"
3. Click Activate DevCom2000 Lite Online (See Figure 1)

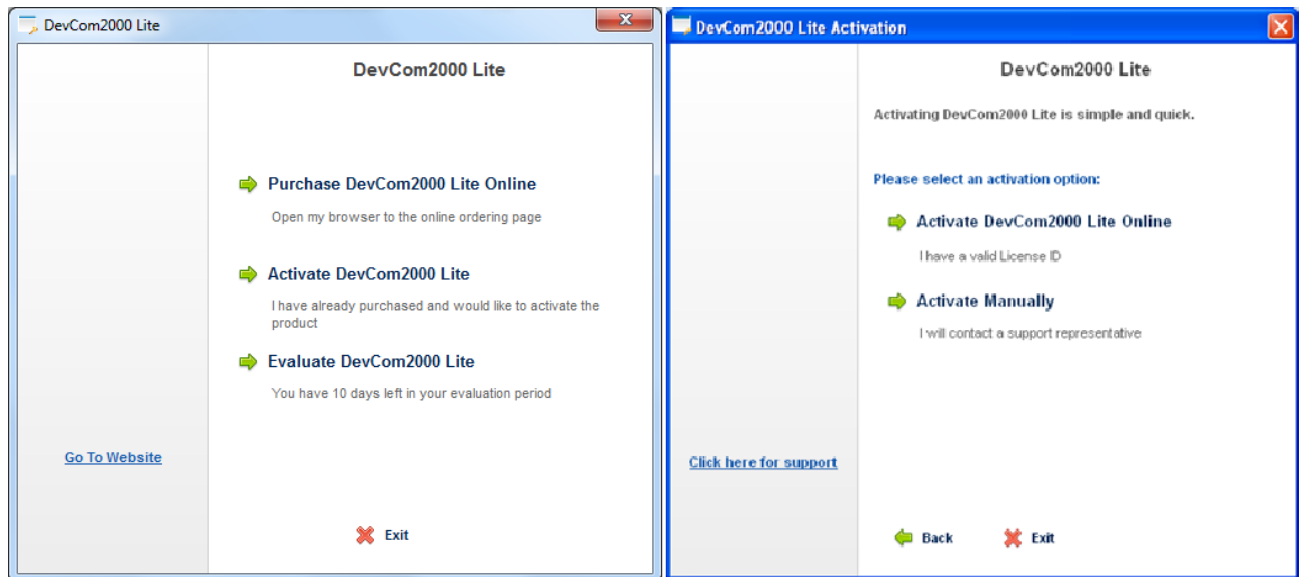

Figure 1 Initial Download Screen

- The license ID and Password will be included in the email with the link to download the software. Enter this information in the Activation Screen (See Figure 2) and click “Continue”.

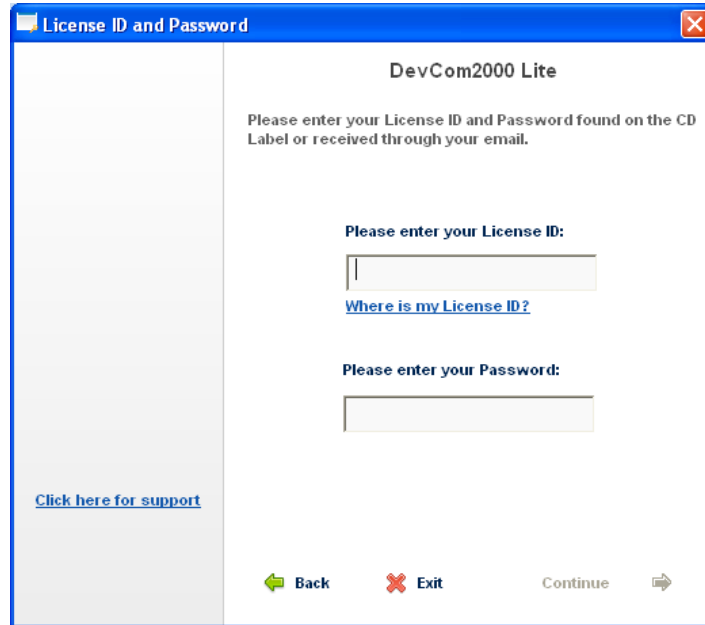

Figure 2 Activation Screen

- By default, the DevCom2000 Lite software is set up for COM99. You will need to change it to the port you will identify when you run the HM Test Software after installing the hardware. Start-up

To run the software from a cold start, click on the DevCom2000-LT icon that was installed on your Desktop.



Hardware Set-up

The 511/521/522 Pressure Transmitter makes use of HART® commands to trim zero and span, monitor pressure spikes, reset to factory settings and store data in the device.

At the time of the publication of this manual, the 511/521/522 is not fully registered with the HART foundation, and therefore can only communicate with the DevCom2000-LT software available directly from Viatran. Once the 511/521/522 Pressure Transmitter is registered with the HART foundation, it will be able to communicate with any handheld device or PC software that is also registered with the HART Foundation.

Viatran offers all of the components required to take advantage of the 511/521/522 Pressure Transmitter external calibration features. All the user needs to supply is a meter which can measure 4-20mA. For a block diagram of a typical set up to communicate with the Viatran 511/521/522 Pressure Transmitter with a PC and HART

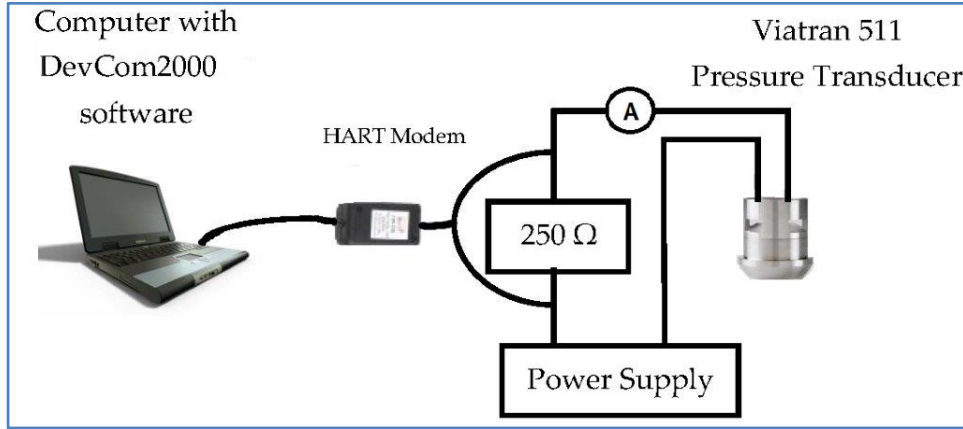

Figure 3 HART setup for communicating with 511/521/522 Pressure Transmitter

Modem, see Figure 3.

The system in Figure 1 is made up of the following essential components:

1. Computer, loaded with the DevCom2000-LT software (Viatran P/N 51DEVCOM20)
2. Power Supply (due to the 250 Ω resistors, the minimum voltage is the minimum excitation voltage, as specified in the Product Data Sheet, plus 5 V)
3. Viatran 511/521/522 Pressure Transmitter
4. HART Modem
5. 250 Ω Resistor
6. Multimeter which can measure 4 to 20 mA

HART® is a registered trademark of the HART® Communications Foundation.

Hardware Set-up using the optional PowerXpress module

Viatran offers an optional integrated solution called “PowerXpress” (Viatran P/N 51PS-EXPRS) which combines some of the components into a kit or module to speed up the setup process. If using the PowerXpress module, the following essential components are required in order to communicate with the 511/521/522 Pressure Transmitter:

1. PowerXpress
 - a. Power supply, which can operate from a PC USB port or 120 Vac
 - b. Built in HART Network load resistor
 - c. Connections for multimeter probes
 - d. Banana plugs for the HART modem
 - e. 110Vac adapter
2. HM-USB-ISO-BP, USB HART Modem, Isolated, Banana Plug Option
3. Multimeter, which can measure 4 to 20 mA

Follow these steps in order to communicate with the 511/521/522 Pressure Transmitter from your PC (see figure 2 for a photo of the correct setup)

1. Install the USB Virtual Serial Port Driver onto the computer
2. Plug the HART modem into the computer
3. Plug the PowerXpress module into the computer
4. Plug the HART modem into modem plugs labeled “Modem Handheld” on the PowerXpress Box.
5. Plug mA meter probes into the PowerXpress module labeled “mAdc” on the PowerXpress Box observing proper polarity.
6. Attach the power clips of the PowerXpress to the power pins of the 511/521/522. The pinout information is indicated on the side of the 511/521/522 as well as in the performance certification included with every 511/521/522.



Figure 4 Example of a set up using the PowerXpress HARTTRIM Rev. B

After you set up your hardware, run the HM Test Software by clicking the HM Test icon on your pc desktop (see example of icon on right), which was installed with the HART modem software. Do this to determine which port is connected to the HART modem.



The software will guide you through a process of trial and error in order to identify the correct port to select for proper operation of the software.

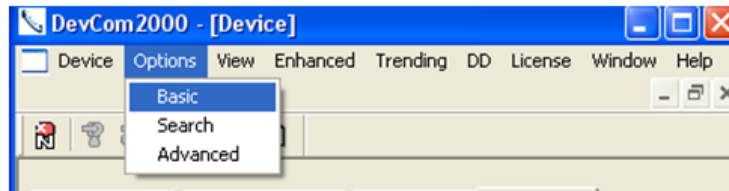

Figure 5 Basic Menu

Once you have identified the correct port, change it from the default which was entered during the software setup by clicking the Options from the top menu, then Basic, and then select the appropriate com port number. (See Figure 5)

Navigating the Software

New Device

If you need to change the device or if you attached the device after bringing up the software, you can direct the software to recognize the device by clicking the “New Device” Icon indicated in Figure 6, or from the top menu select Device → New Device.



The software will automatically load your new device and take you to the initial [Viatran View] screen.

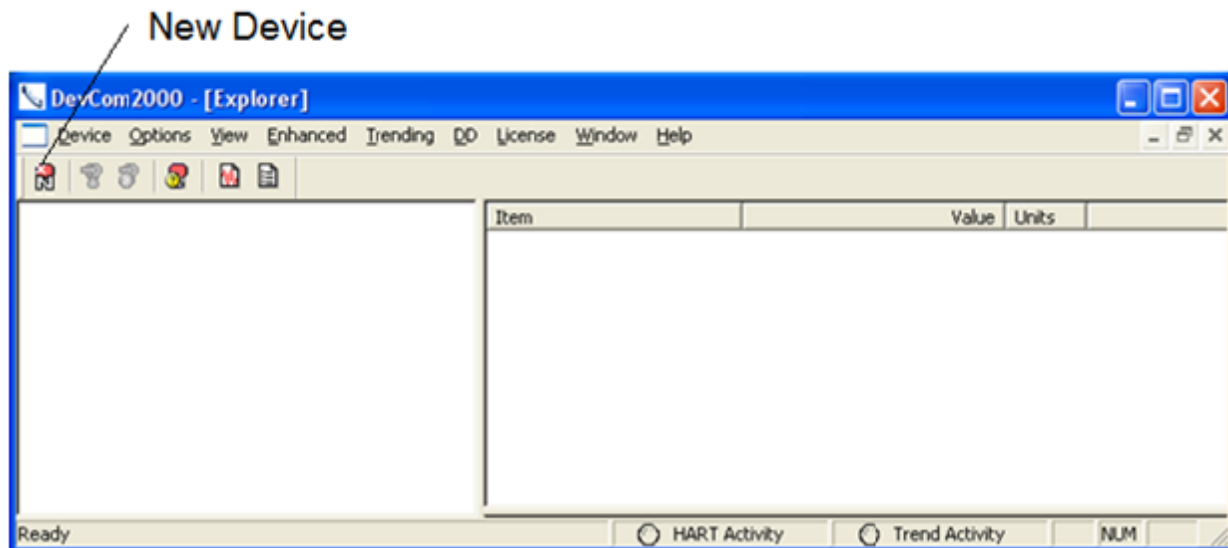

Figure 6 New Device

Views

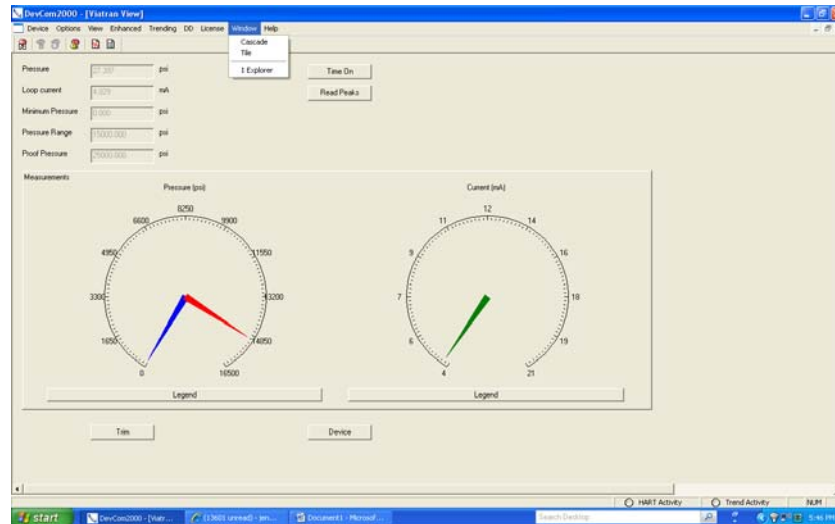

Figure 7 Initial Screen – [Viatran View]

There are two views available to navigate through the software, one is called [Viatran View] and the other one is called [Explorer]. Both provide the same functions, so you have the option of selecting the type you prefer. The view called [Viatran View] is a more user friendly interface developed by Viatran for users unfamiliar with standard HART menus. The view called [Explorer] is more like the menu you would get if you were using a handheld HART controller. To change the view to your preferred type, click the Window option from top pulldown menu, and select either Explorer or Viatran View. You can also click the pulldown menu option “Enhanced” to switch to the Viatran View from the Explorer View.

For additional information on the features of the software, refer to the DevCom2000 User manual

Initial Screen

Figure 8 shows what the initial screen, [Viatran View], will look like when the software connects to the Viatran 511/521/522.



Figure 8 Initial Screen

The information provided on this screen is as follows:

Pressure – The pressure being applied to the device in real time. There is also a depiction of a dial gage that provides this exact same data in graphic form.

Loop current – This is the current recorded by the software, it should not be used to calibrate the device. Use the mA meter that the user provides and installs externally in the loop.

Minimum pressure – The lowest rated pressure for the device for which the standard output should read 0 psi

Pressure Range – The highest rated pressure for the device

Proof pressure – The maximum pressure that can be applied to the device without damaging the unit.

There are also buttons which take you to different screens, each of which are described in detail below.

How to read the Pop-Up Screens

Figure 9 shows a typical pop-up screen. The top section displays the information generated by the command initiated by the prior screen. In this case it is the Time On reading. The bottom statement directs the user to make a selection of "OK" or "Abort", with an additional "Help" button. If you have read the data and are ok to proceed to next step, select "OK". If you click "Abort" you will leave the screen without performing the action.

The "Time On" and "Read Peaks" Screens

If you click on the "Time On" button, you get a screen that provides you with the total number of hours the unit has been on since it left the factory as a new unit. This number will not be reset if the unit is returned for repair. (Figure 9)

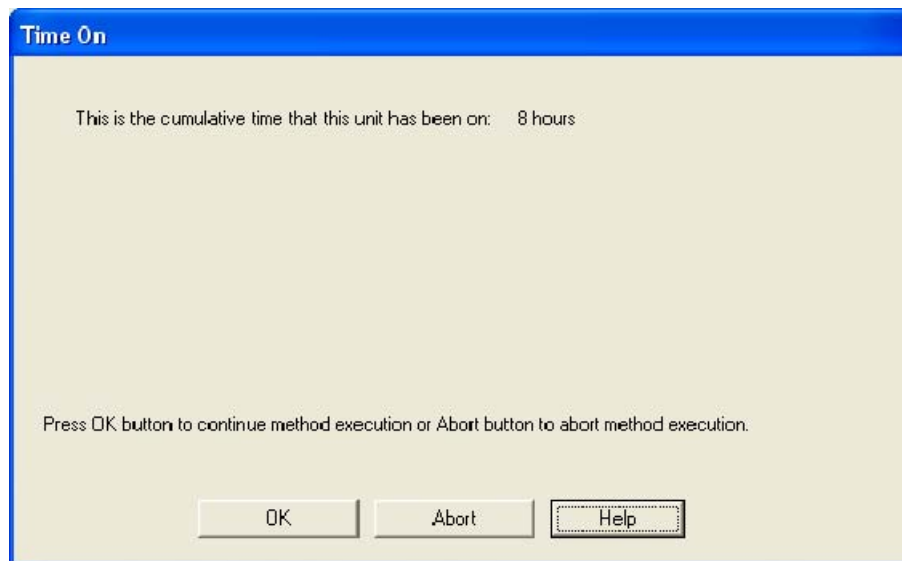

Figure 9 Time On pop up screen

If you click the "Read Peaks" button, you get a screen that provides you with the total number of hours that the unit has been on (Time on). You also get a tally of the 4 peak pressures that occurred since Time On, and the hour in which the peak occurred. The software will only record the largest peak within each hour in order to prevent catching peaks that extend over a few minutes and filling all four slots with what is actually only one event. There are four time slots available to record peaks, so if all four slots are filled, and higher peaks are recorded, the higher peak will replace the lowest peak from a prior event. (See Figure 10)

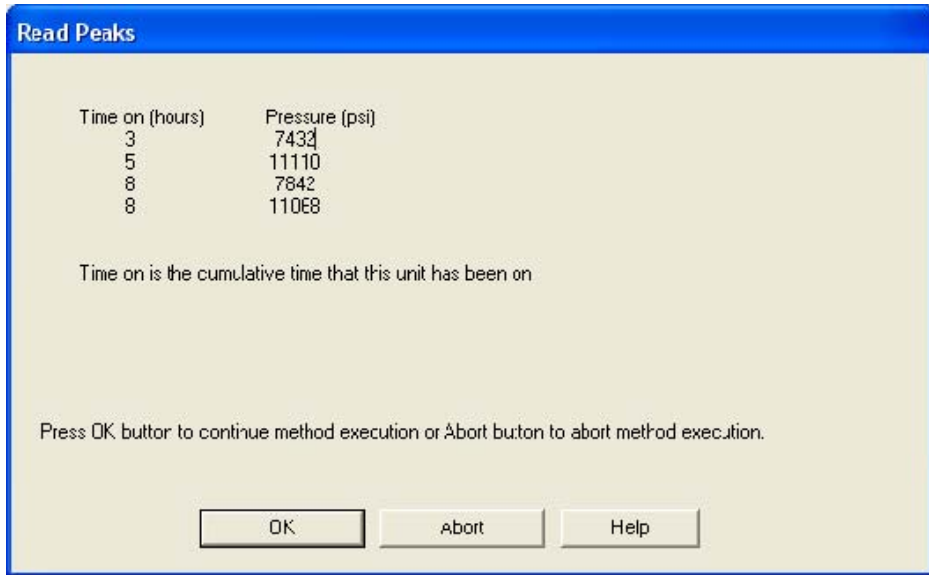

Figure 10 Read Peaks Screen

There is no feature in the 511/521/522 device that provides the date and time of the peaks. If you want to determine when peaks actually occurred, you can create a manual log in one of the user fields whereby you type in the dates and times that the 511/521/522 device has been turned on and off and cross reference those dates and times to the values in the Time on column of the “Read Peaks” screen. More information on user fields is provided in the “Device” section.

The maximum peak reading will be 140% of the rated pressure or pressure range of the unit.

Trim Procedure

On the bottom left of the initial screen is a button marked Trim. By clicking on the “Trim” button you will be brought to the Trim Screen. (See Figure 11)

The Trim function provides the ability to make adjustments to the zero and span outputs.

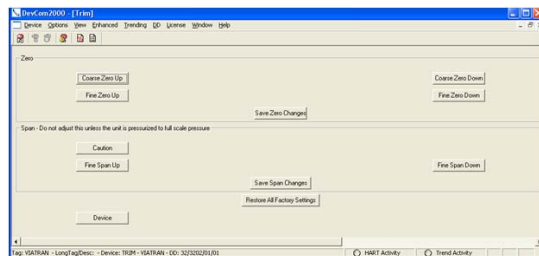

Figure 11 Trim Screen

Zero Adjust

A zero adjust should be performed before the span is adjusted. Follow the steps below to trim the **zero** output:

1. Vent any pressure applied to the sensor.
2. To adjust the zero reading click on either the coarse or fine zero up or down menu button to increase or decrease the milliamp output of the unit. A pop-up box will be displayed briefly each time you click on an up or down box in this screen telling you your adjustments were implemented. (See Figure 12) Continue until your device is as close as possible to the desired output.

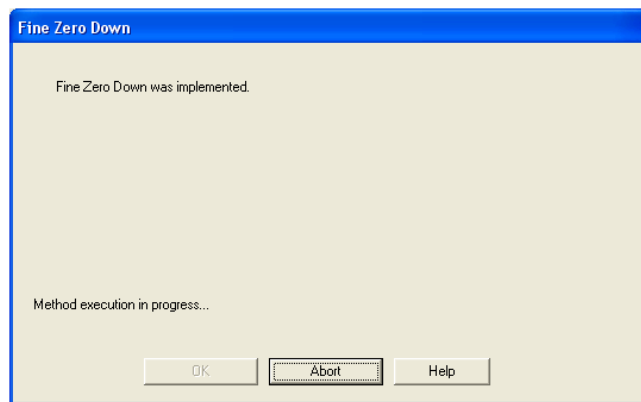

Figure 12 Trim Implemented

3. The zero setting must be stored in the 511/521/522 by clicking the Save Zero Settings button. If the settings are not saved when the unit is powered down, it will go back to the last saved setting when it is powered back up.

Span Adjust

The calibration circuit of the Model 511/521/522 may be used to determine if a calibration of the unit is required. Please reference the 511/521/522 manual to activate the calibration feature. The milliamp output of the unit should be close to the current that is indicated on the Performance Certificate for the 511/521/522. If it is not this indicates the product should be calibrated.

Tip: You may want to record the calibration output and pressure from the Performance Certificate into one of the user fields. These fields are described in the Device Section.

If the current measurement is not within tolerance it indicates, the unit is out of calibration and must be connected to a calibrated pressure source to adjust the span. **Do not adjust the Span without a calibrated pressure source.**

Follow the steps below to trim the **span output**:

1. Apply full scale pressure to the sensor.
2. To adjust the span reading click on either the coarse or fine zero up or down menu button to increase or decrease the milliamp output of the unit. A pop-up box will be displayed briefly each time you click on an up or down box in this screen telling you your adjustments were implemented. (See Figure 12) Continue until your device is as close as possible to the desired output.

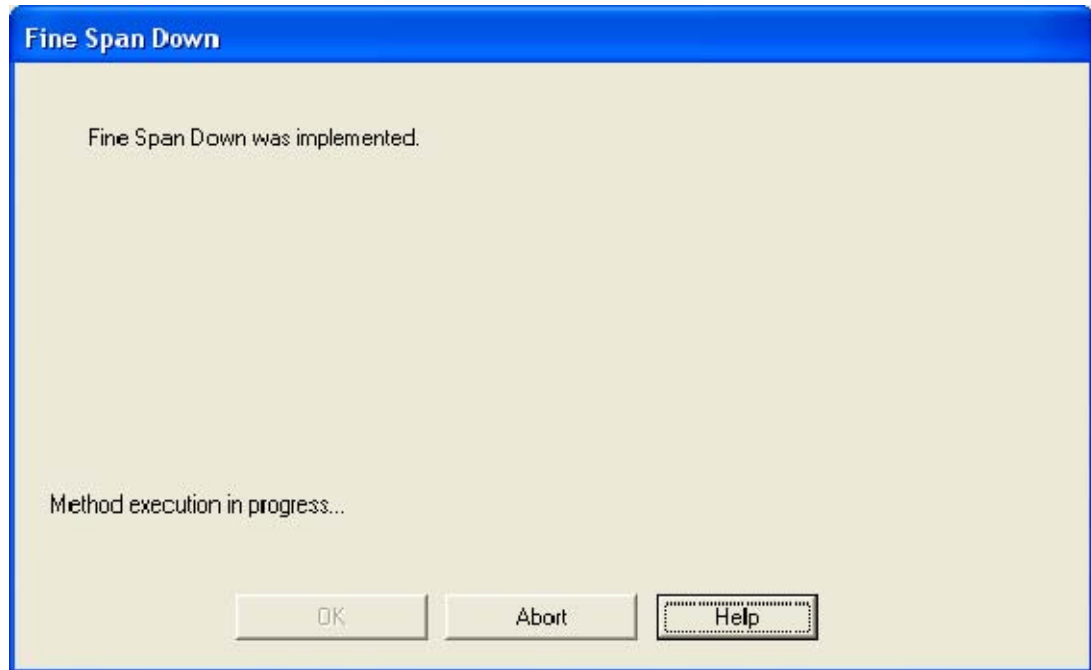

Figure 13 Span Implemented

3. The span setting must be stored in the 511/521/522 by clicking the Save Span Settings button. If the settings are not saved when the unit is powered down, it will go back to the last saved setting when it is powered back up.

Once you have made necessary adjustments to the span setting, you should vent the pressure applied to the sensor and recheck the zero output.

Restore Factory Settings

The factory set zero and span may be restored by navigating to Trim and clicking the “Restore All Factory Settings” menu item (Figure 14). You will be asked to confirm that you wish to perform this operation. If it has been more than 12 months since the unit has been calibrated by Viatran or an authorized Viatran Repair Center, you may not want to restore factory settings as they may not accurately reflect the pressure being applied to the sensor. These calibration fields are only updated when the product is calibrated by Viatran or an authorized Viatran Repair Center.

After performing the calibration, it is recommended that you make note of the calibration date and settings in the User fields of the 511/521/522.

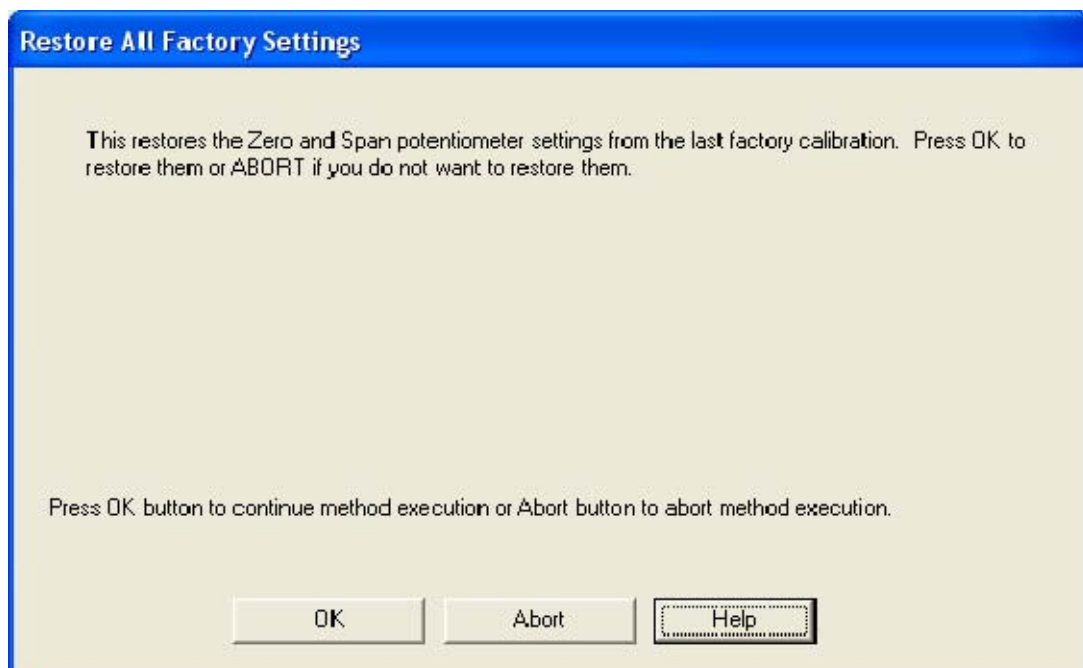

Figure 14 Restore All Factory Settings

Device

User Information

Figure 15 shows the Device → User Information display, which is accessed by clicking on the Device button in the main screen.

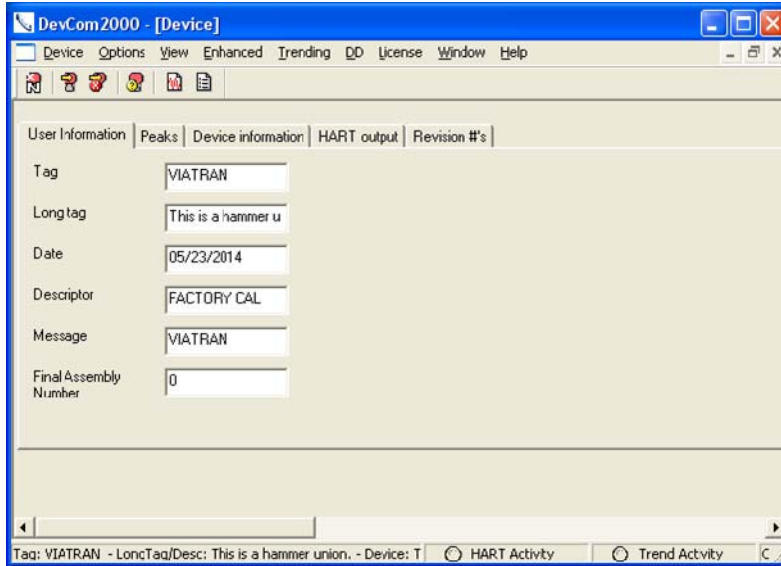

Figure 15 Device User Information

The first tab on this screen is titled “User Information”. User information is information that is saved in the device and the user can change. The field sizes are as follows:

Field Name	Size
Tag	8 characters
Long Tag	32 characters
Date	10 characters
Descriptor	16 characters
Message	32 characters
Final Assembly Number	0 to 16777215

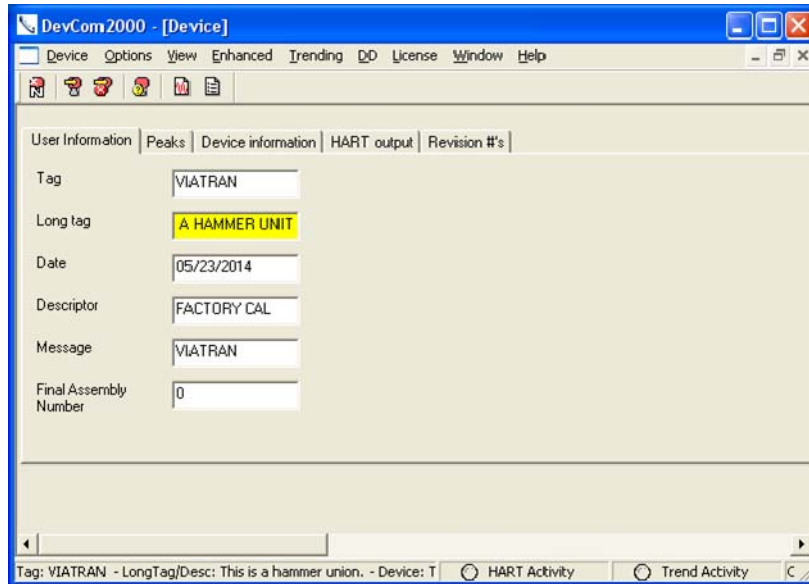

Figure 16 User Information with edit

To change the information, click in the box that you want to edit, or double click to select the whole field. Make the edits you want and then click enter or click in another block and the field that has been changed will turn yellow, as shown in Figure 16. The yellow indicates which fields contain information that is different than what is in the unit. By clicking the Send to Device icon in the top menu (shown at right) the information will be transferred to the device.



You can cancel your edits by clicking the cancel edits icon in the top menu (also shown at right).



Peaks

This tab provides the Peak data that is recorded by the 511/521/522 device. Reference the section entitled “Time on” and “Read Peaks” for a description of this feature. In this screen, you need to push the “Refresh” button to get updated Peak information.

Device Information

This is a required screen with fields that cannot be modified by the user.

HART Output

This is a required screen with fields that should not be modified by the user.

Revision #'s

This is a required screen with fields that cannot be modified by the user.

Questions/Help

If you have questions concerning the installation of ProComSol software or its features, refer to the DevCom2000 User manual or contact ProComSol using the information provided below:

ProComSol, Ltd

Process Communications Solutions

13001 Athens Ave
Suite 220
Lakewood, OH 44107
USA

Phone: 216.221.1550
Toll Free: 877.221.1551
Fax: 216.221.1554
E-mail: sales@procomsol.com

If you have questions concerning the Trim function or the 511/521/522 Pressure Transmitter device, contact Viatran using the information provided below:



3829 Forest Parkway, Suite 500
Wheatfield, NY 14120
International: 1-716-629-3800
Toll Free: 1-800-688-0030
Fax: 1-716-693-9162
Email: solutions@viatran.com