



INSTALLATION DATA MANUAL
MODEL 118/218/318
PRESSURE TRANSMITTER

3829 Forest Parkway, Suite 500
Wheatfield, NY 14120
Int'l: 1-716-629-3800
Toll Free: 1-800-688-0030
Fax: 1-716-693-9162
www.viatran.com
solutions@viatran.com

VIATRAN MODEL 118, 218, 318

NOTE: All information contained in this document is representative of a **standard** Model 118, 218, 318. If the product you ordered has special requirements or modifications, refer to the Laser Marked information on the product and your purchase order for possible alteration to the products configuration. Failure to verify product configuration before installation may cause permanent product damage and in most cases, void the manufacturer's product warranty. If you are unsure or have questions about your product, please contact our Application Engineers for assistance.

MODEL 118	MODEL 218	MODEL 318
------------------	------------------	------------------

Connector: WK4-32S	Connector: WK6-32S (218-28) WK7-32S (218-15)	Connector: WK4-32S
------------------------------	---	------------------------------

Input: 10 V nominal, 15 V Maximum	Input: 10-48 VDC	Input: 9.5 - 36 VDC
--	----------------------------	-------------------------------

Output: 1 - 3 mV/V	Output: 0 - 5 VDC	Output: 4 - 20 mA
------------------------------	-----------------------------	-----------------------------

Cal Shunt: 80% FSPR, apply resistance across Pins 2 & 4	Cal Shunt: 80% FSPR, by shorting Pins 5 & 6	Cal Shunt: 100% FSPR, by shorting Pins 3 & 4
---	---	--

Sensor Construction:
Bonded Foil Strain Gage

Wetted Parts:
303, 15-5 PH, 17-7 PF SST, and Buna-N O-Ring
(range dependent)

Pressure Connection:
1/4" NPT Female

Electrical Mating Connection:
Model 118: WK4-21C or equal
Model 218-28: WK6-21C or equal
Model 218-15: WK7-21C or equal
Model 318: WK4-21C or equal

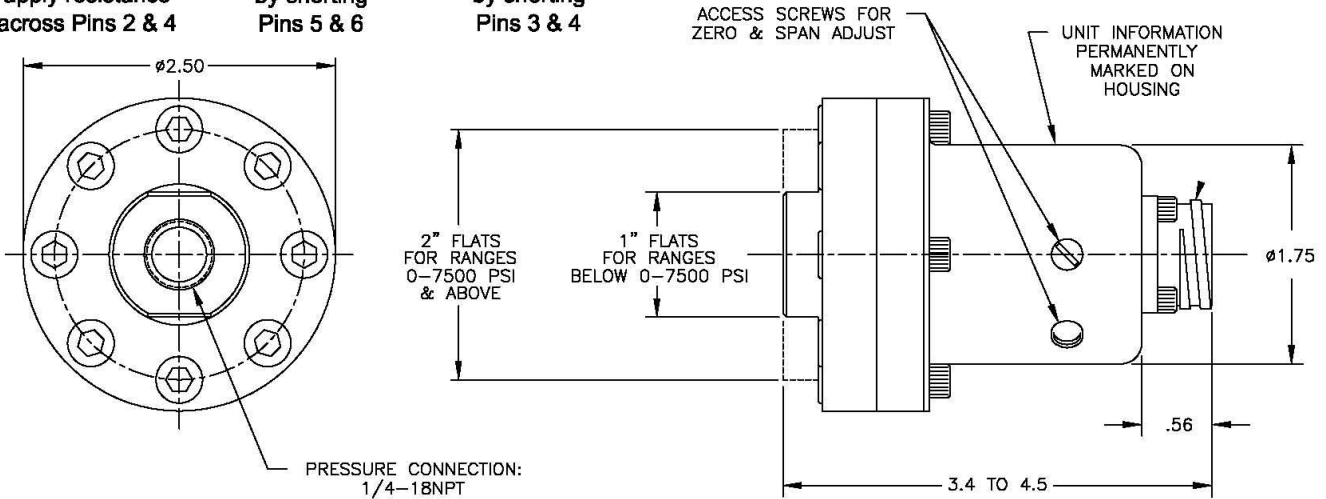

INSTALLATION DATA - VIATRAN MODEL 118

This section covers Model 118, which provides a millivolt per volt (mV/V) signal output, by means of an active four-element Wheatstone Bridge circuit.

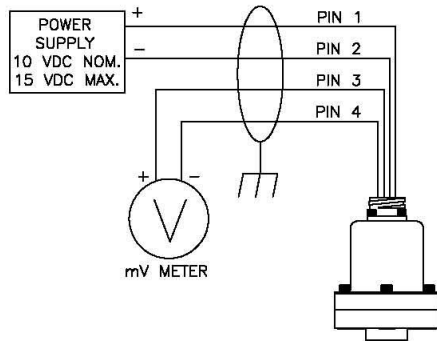

Figure 2 - Standard Connection Diagram

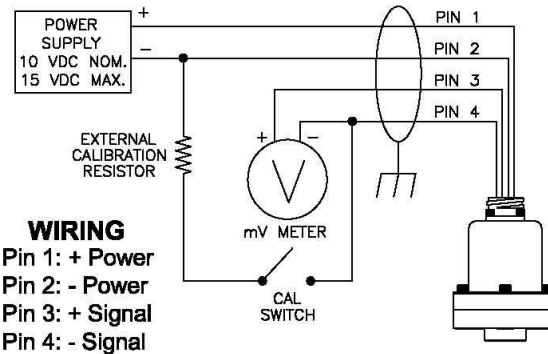

Figure 3 - External Calibration Shunt

SHUNT CALIBRATION

The Model 118 is equipped with an external shunt calibration. This feature allows field calibration to be performed by electrically simulating pressure. When the shunt calibration is activated, the transducer bridge is unbalanced by an amount equivalent to the application of approximately 80% of full scale pressure. The exact pressure and output values are listed on the Performance Certificate.

External shunt calibration is achieved by placing the specified resistor across Pins 2 and 4 of the electrical connector. The value of the resistor is listed on the Performance Certificate. Internal shunt calibration is optional on the Model 118. Units with internal shunt calibration have a 6 pin connector. The shunt calibration resistor is built into the transducer and the circuit is activated by connecting (shorting) Pins 5 and 6 of the connector.

After calibration, the shunt calibration circuit should be deactivated for normal operation.

INSTALLATION DATA - VIATRAN MODEL 218

This section covers Model 218 with electronics designed for a voltage signal output by means of a signal conditioner.

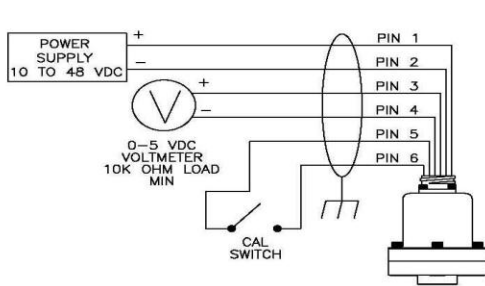

Figure 4 - Connection Diagram

WIRING

Pin 1: + Power
Pin 2: - Power
Pin 3: + Signal
Pin 4: - Signal
Pin 5: Calibration
Pin 6: Calibration

The negative input (Pin 2) and output (Pin 4) terminals are common.

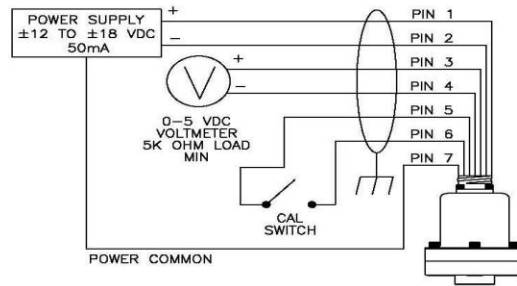

Figure 4b - Connection Diagram for Bi-Polar Models 2xx-

WIRING

Pin 1: + Power
Pin 2: - Power
Pin 3: + Signal
Pin 4: - Signal
Pin 5: Calibration
Pin 6: Calibration
Pin 7: Power Common

FIELD CALIBRATION

The Model 218 Series Transducers are provided with a unique feature that permits field calibration to be performed without the need of a pressure source, by electronically simulating pressure. The nylon access screws should be removed and the pressure port shall be vented to zero pressure. For transducers measuring absolute pressure, a full vacuum must be applied to the pressure port. Connecting (shorting) the calibration terminals (Pins 5 and 6), produces an output equivalent to approximately 80% of full-scale pressure. Refer to the performance certificate, which was supplied with the transducer, for the exact calibration output. If the certificate is unavailable, the calibration output can be calculated by using the following formula: $\text{Volts DC} = (\text{Cal pressure from transducer label} / \text{pressure range}) \times 5$. Thus, following adjustment of zero output for zero pressure, the calibration circuit may be activated and the gain or span adjustment screw can be turned until the correct calibration output appears at the output terminals. The calibration terminals should then be disconnected and the zero adjustment reconfirmed. *Note - the calibration circuit shall be deactivated during normal operation. The nylon cover screws, removed to access zero and span adjustments, shall be reinstalled after calibrating the transducer.*

INSTALLATION DATA - VIATRAN MODEL 318

This section covers Model 318 with electronics designed for a 2-wire, 4-20mA current loop signal output.

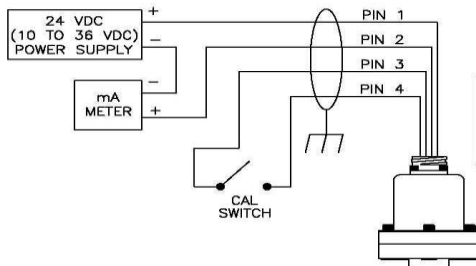

Figure 5 - Connection Diagram - Any Meter

WIRING
Pin 1: + Power/Signal
Pin 2: - Power/Signal
Pin 3: Calibrate
Pin 4: Calibrate

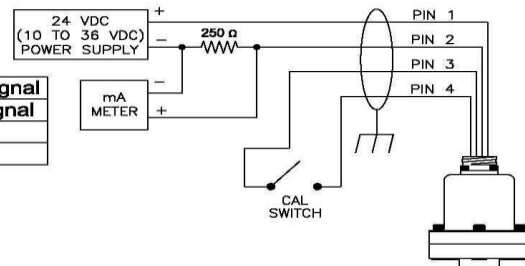

Figure 6 - Connection Diagram - Volt Meter (1-5 VDC Output)

SHUNT CALIBRATION

The Model 318 provides a unique internal shunt calibration resistor that allows field calibration to be performed by electrically simulating pressure. The connector shall be connected as shown in Fig. 5. The nylon access screws should be removed and the pressure port shall be vented to zero pressure. For transducers measuring absolute pressure, a full vacuum must be applied to the pressure port. Connecting (shorting) the calibration terminals (Pins 3 and 4) unbalances the transducer bridge by an amount equivalent to the application of approximately 100% of full-scale pressure. See the performance certificate, which was supplied with the transducer, for the exact milliamp output and adjust the span control accordingly. If the certificate is unavailable, the milliamp output can be calculated by using the following formula: $\text{mA} = ((\text{Cal pressure} / \text{pressure range}) \times 16) + 4$. Thus, following adjustment of zero output for zero pressure, the calibration circuit may be activated and the gain or span adjustment screw can be turned until the correct calibration output appears at the output terminals. The calibration terminals should then be disconnected and the zero adjustment reconfirmed. *Note - the calibration circuit shall be deactivated during normal operation. The access screws should be reinstalled after calibrating the transducer.*

ACCESSORIES - OPTIONAL EQUIPMENT

Mating Electrical Connector (118, 318)	10MSWK0204
Mating Electrical Connector (218)	10MSWK0206
Mating Electrical Cable Assembly (118, 318)	230005.001
Mating Electrical Cable Assembly (218)	230006.001
Mounting Bracket	080002.001
Protective Cover	03XL-20RBC
Digital Meter	Consult Factory

MAINTENANCE AND REPAIR

All Viatran transmitters have been designed to function free from routine or scheduled maintenance. Simple cleaning of the electrical connector, pressure port threads and pressure cavity on an as needed basis will provide many years of satisfactory performance. Protecting the product from continued exposure to moisture or fluids at the electrical connection, breather area (model dependent) will eliminate premature internal failure of the product. Generally any time the product is removed from service the connector and pressure port threads should be cleaned and the pressure cavity flushed with a 316SS and/or O-Ring (material model dependent) compatible cleaner to prevent media buildup. During the cleaning process only a soft, lint-free cloth is recommended. Never use a coarse of stiff bristle brush to clean media from the diaphragm surface.

It is suggested that the calibration be verified on a usage dependent schedule. If the product is in continuous service 7 days a week, then calibration verification may be necessary every 6 to 8 months. If the product is in a lab test environment a more lenient verification schedule would be appropriate. In all instances the performance of the product will depend on the individual application or process in which it is installed. More continued usage would require a shorter period between calibration verification and product maintenance.

If a product is perceived to be exhibiting problems, it can be returned to Viatran for analysis and/or repair. It is suggested that only Viatran personnel attempt repair of the product. Any damage resulting from customer disassembly would result in a loss of coverage under the warranty policy. All Viatran products are able to be repaired at minimal cost if simple cleaning and precautions are taken in the handling and application of the product. Older products returned for repair are updated to current specifications unless the repair cost would outweigh the cost of a new replacement model. Products returned for repair should include information on the person to contact for repair quote approval, the individual to contact if Viatran's technical staff requires additional information during analysis, and a brief description of the problem associated with the product's failure.

WARRANTY

Viatran Corporation warrants that its products shall be free from defective workmanship and/or material for a period of twelve (12) months from the date of shipment, provided that Viatran's obligation hereunder shall be limited to correcting any defective workmanship and/or replacing any defective material f.o.b. factory. No allowance will be made for any expense incurred for correcting any defective workmanship and/or material without written consent by Viatran. This warranty is in lieu of all other warranties expressed or implied.

REPAIR INSTRUCTIONS

Viatran's Transmitters are designed to be easily repaired and recalibrated if necessary. If a failure occurs, the transmitter should be returned to the factory for inspection and testing. Please contact the Customer Support Department at 1-800-688-0030, for a return tracking number and/or a repair cost estimate. A nominal inspection fee is charged on all units returned to the factory which are not subsequently repaired.