



**INSTALLATION DATA MANUAL**

**MODEL 554**

**PRESSURE TRANSMITTER**

**38 Forge Parkway  
Franklin, MA 02038  
Int'l: 1-716-629-3800  
Toll Free: 1-800-688-0030  
Fax: 1-716-693-9162  
[www.viatran.com](http://www.viatran.com)  
[solutions@viatran.com](mailto:solutions@viatran.com)**

## COMPANY BACKGROUND

Viatran is an ISO 9001:2008 certified company committed to providing high quality pressure transducers and transmitters. Established more than 40 years ago, Viatran has built its reputation on providing durable, and accurate pressure sensing devices. Our products are often specifically specified by integrators and engineering firms for applications ranging from the offshore oil rigs to pump control to tank and well level measurement. Viatran is often called on for custom modifications for applications where standard products are not available.

## CUSTOMER SERVICE

Orders for additional units or accessories can be placed by calling customer service at 1-800-688-0030 or by fax at 1-716-693-9162. Orders can also be placed by contacting a local representative in your area. To find the nearest representative visit our web site at [www.viatran.com](http://www.viatran.com) and click on rep search.

## PRODUCT OVERVIEW

**MANUAL SCOPE:** Information contained in this document is representative of a standard Model 554. If the product has special requirements or modifications, refer to the permanently marked information on the product and your purchase order for possible alteration to the product's configuration. Failure to verify product configuration before installation may cause permanent product damage and in most cases, void the manufacturer's product warranty. If you are unsure or have questions about your product, please contact your Application Engineer at 1-800-688-0030 for assistance.

Remove and retain all enclosed instruction manuals and performance certificates. These documents provide important information on the product's calibration, operation, safety precautions, recommended maintenance, re-calibration requirements, repair service instructions and warranty information. These documents are updated from time to time as changes to the product occur and should be reviewed at receipt so that proper and safe installation can occur.

**PRODUCT DESCRIPTION AND GENERAL USE:** Viatran's model 554 uses a 17-4 pH stainless steel strain gage diaphragm sensor (Inconel X750 optional). The 554 is designed to measure process pressures in applications compatible with 17-4 pH stainless steel. The 554 has a standard output of 4-20 mA. The standard electrical connection are 3' pigtail leads potted in a 1/2" NPT male conduit connection which can be easily connected inside a conduit connection box. Model 554 is approved by FM as non-incendive and intrinsically safe. Viatran provides many standard options including alternate connectors to custom fit your unit. The 554 is specially designed for the pulp and paper industry.

## BASIC OPERATION & INTERNAL CALIBRATION CIRCUIT

*Note: The casting of the module has raised numbers at the adjustment screw positions. Those numbers reflect the following functions:*

Screw 1: Top Left, Coarse Zero Pot (CCW - Lower, CW - Raise)

Screw 2: Top Right, Fine Zero Pot (CCW - Lower, CW - Raise)

Screw 3: Lower Left, Internal Cal. Activation Pot (12 or 6 o'clock position – Disengage; 3 o'clock position - Engage)

Screw 4: Lower Right, Span Adjustment Pot (CCW - Lower, CW - Raise)

1. Outside of using the calibration circuit or the availability of a metrology lab for obtaining a pressure (Full Scale) reading, no object should be used to physically move the sensor. The diaphragm can be damaged.
2. Once proper connections and power are applied, the unit should begin to function.
3. Check the zero (4.00 mA) with the performance certificate to verify condition. If it is out of specification from the performance certificate, use the coarse and fine zero adjustment screws to obtain the proper reading.
4. With no pressure applied, engage the calibration circuit by slowly rotating the calibration screw until the current output rises to about 8.80 mA's (for a standard calibrated range). Check the reading with the performance certificate. If the reading is off, adjust the span screw to raise or lower the reading – return the calibration circuit to the original position.
5. When making zero and/or span adjustments, there may be some interaction between the readings – repeat adjustments if needed.
6. Always return the calibration screw to off or full CCW position before installing the transmitter into the application. Note: This is a common reason for incorrect start-up readings. The calibration circuit must be deactivated for the product to perform properly.
7. Once the product has been tested and functionality verified, the power and meter connections may be removed and the product reconnected to the instrumentation loop.

## NON-STANDARD RANGE (NSR) CALIBRATION

**NSR Definition:** A non-standard range is a customer request to provide alternate scaled readings. Through the use of a single transmitter, numerous pressure ranges can be set-up. Depending upon the model, the transmitter can be scaled down to any pressure range, from three times to five times the original range. Only NSR requests for ranges less than the sensor rated range are recommended and in most cases possible. The NSR is possible due to the ability of the adjustment screws to alter where the zero and span will fall. Refer to the below example for field NSR calibration.

**NSR EXAMPLE:** You have Viatran's Model 554 with a standard range of 0 to 300 PSI. You would like to set an NSR of 0 to 150 PSI. Refer to the Performance Certificate and obtain the following:

Zero = 0 PSI = 4.00 mA

Full Scale = 300 PSI = 20.00 mA

Cal Value = 90.04 PSI = 8.81 mA

In order to recalibrate the transmitter, you must determine the cal reading in mA's at the NSR range. This is done by calculating what the cal output should be at the NSR range. For the example listed, the standard calibration value is set to represent 90.04 PSI. Once internally set, the calibration (Cal) will always represent this pressure.

Use the formula:  $\text{Cal mA's} = [(16 \times \text{Standard Cal Pressure}) / \text{desired range}] + 4$

Substitute Actual Numbers:  $\text{Cal mA's} = [(16 \times 90.04) / 150] + 4$

$\text{Cal mA's} = (1440.64 / 150) + 4$

$\text{Cal mA's} = 9.604 + 4$

$\text{Cal mA's} = 13.604 \text{ mA's}$

The zero would be set for 4.00 mA's, and the calibration circuit will read (after adjusting span) 13.604 mA's when activated. This would provide a new NSR range for the unit of 4-20 mA's over 0-150 PSI.

# INSTALLATION DATA - VIATRAN MODEL 554

Note: The drawing below is for informational purposes only and is not to scale.  
All dimensions are nominal, in inches and for reference purposes only.

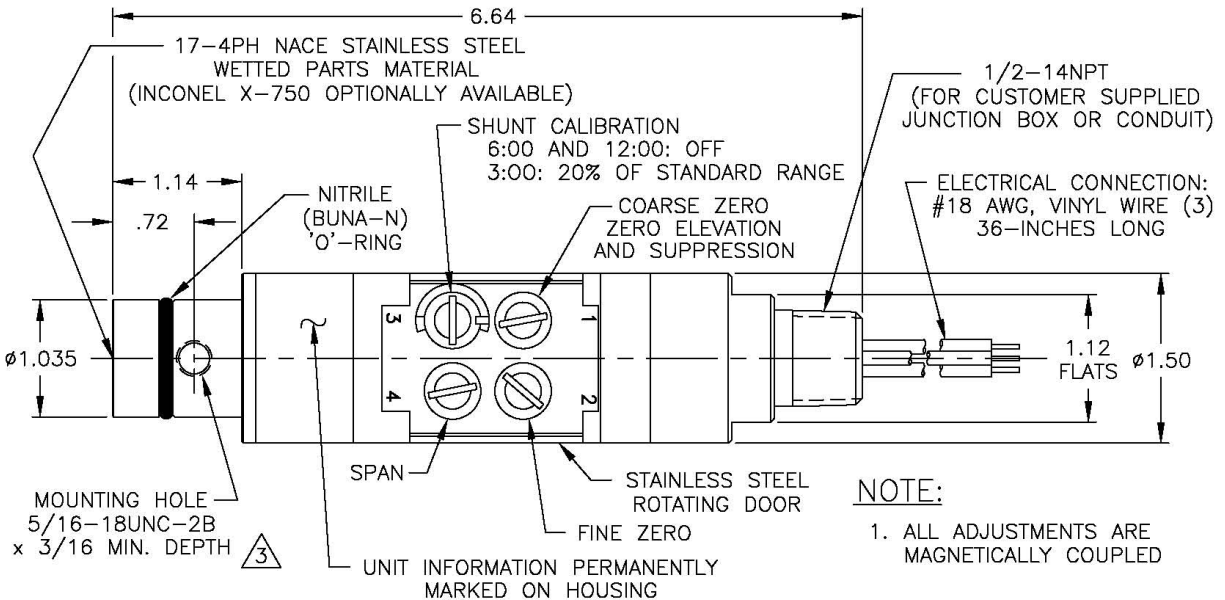

**Sensor Construction and Wetted Materials:**  
17-4 Stainless Steel  
**Pressure Connection:**  
1" PMC  
**Electrical Mating Connection:**  
Acceptable 18AWG wire termination connection  
1/2" NPT (M)

## CONNECTION DIAGRAMS & WIRING

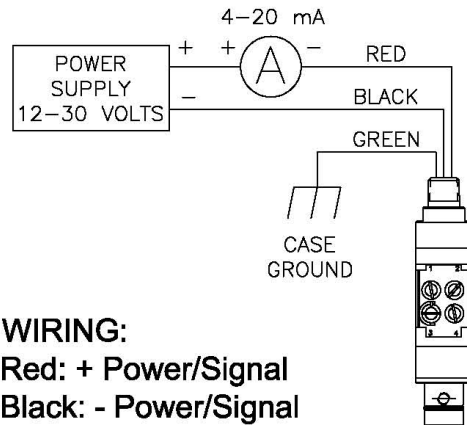

**WIRING:**  
Red: + Power/Signal  
Black: - Power/Signal  
Green: Case Ground

*Note: If the unit is certified for hazardous locations as Intrinsically Safe, use the enclosed connection diagram. Only the pressure transmitter is considered to have the Factory Mutual safety ratings. If you have purchased a transmitter and isolator/remote seal, they have not been tested as a system for safety certification. The end-user shall be responsible for verifying the system is safe and installed accordingly.*

## HANDLING REQUIREMENTS AND CAUTIONS

1. All electrical & pressure connections should be compatible with the model specifications as outlined.
2. The product's internal electrical circuitry is DC isolated from case ground. It is recommended that the case ground wire be connected to earth ground at the cable termination, as this is an integral part of the internal surge protection and noise immunity features.
3. At no time should an object be pressed against the sensing area to deflect the sensor (to test or simulate pressure), as on some models permanent damage to the sensing diaphragm may occur.
4. When shipped in quantities, units should be packaged individually to eliminate possible damage.

## MECHANICAL INSTALLATION

The model 553 is mounted in a 1 inch PMC process connection. The unit may be mounted directly to the process fitting in any orientation with negligible positioning error. To mount the unit, first lubricate the o-ring with light oil or other acceptable lubricant. The medium to be measured can also be used. Align the mounting hole with the hole in the nipple adapter. Insert the 5/16-24 bolt into the hole and tighten to 120 - 140in./lb.

## ELECTRICAL CONNECTIONS

The standard wiring of your Viatran pressure transmitter is outlined on page 3. If your unit was ordered with an alternate connector or special wiring refer to the wiring information permanently marked on your unit. The 554 transmitter can be powered by a DC power supply ranging from 12 to 30 volts. With a 4-20 mA device please refer to the load/voltage chart (below) to identify the required input voltage for your specific system load.

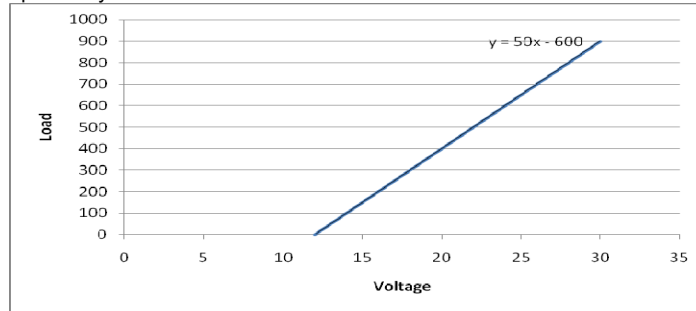

## TECHNICAL SUPPORT

Technical assistance is available Monday-Friday 8:00 AM to 5:00 PM (Eastern) from our knowledgeable factory personnel to answer any of your application or installation questions. Our toll free number is 800-688-0030. Questions or additional documentation can also be requested via e-mail at [solutions@viatran.com](mailto:solutions@viatran.com).

## MAINTENANCE AND REPAIR

All Viatran transmitters have been designed to function free from routine or scheduled maintenance. Simple cleaning of the pressure sensor on an as needed basis will provide many years of satisfactory performance. Protecting the product from continued exposure to moisture or fluids at the electrical connection will eliminate premature internal failure of the product. Generally any time the product is removed from service, the pressure sensor should be flushed with a stainless steel compatible cleaner to prevent media buildup. During the cleaning process only a soft, lint-free cloth is recommended. Never use a coarse or stiff bristle brush to clean media from the diaphragm surface.

It is suggested that the calibration be verified on a usage dependent schedule. If the product is in continuous service 7 days a week, then calibration verification may be necessary every 6 to 8 months. If the product is in a lab test environment, a more lenient verification schedule would be appropriate. In all instances the performance of the product will depend on the individual application or process in which it is installed. More continuous usage would require a shorter period between calibration verification and product maintenance.

If a product is perceived to be exhibiting problems, it can be returned to Viatran for analysis and/or repair. It is suggested that only Viatran personnel attempt repair of the product. Any damage resulting from customer disassembly would result in a loss of coverage under the warranty policy. Older products returned for repair are updated to current specifications unless the repair cost would outweigh the cost of a new replacement model. Products returned for repair should include information on the person to contact for repair quote approval, the individual to contact if Viatran's technical staff requires additional information during analysis, and a brief description of the problem associated with the product's failure.

## REPAIR INSTRUCTIONS

Viatran's Transmitters are designed to be easily repaired and recalibrated if necessary. If a failure occurs, the transmitter should be returned to the factory for inspection and testing. Please contact the Customer Support Department at 1-800-688-0030, for a return authorization number and/or a repair cost estimate. A nominal inspection fee is charged on all units returned to the factory which are not subsequently repaired.

## WARRANTY



Viatran Corporation warrants that its products shall be free from defective workmanship and/or material for a period of twelve (12) months from the date of shipment, provided that Viatran's obligation hereunder shall be limited to correcting any defective workmanship and/or replacing any defective material f.o.b. factory. No allowance will be made for any expense incurred for correcting any defective workmanship and/or material without written consent by Viatran. This warranty is in lieu of all other warranties expressed or implied.

## OPTIONAL CERTIFICATIONS

**554TF(A)**  
 [All product  $\geq$ 300 PSIS]  
  
 APPROVED  
 INTRINSICALLY SAFE FOR USE IN  
 CLASS I,II,III, DIV. 1, GROUPS A,B,C,D,E,F,G  
 CLASS I, ZONE 0, AEx ia IIC T4, Ta=80°C,  
 T5, Ta=40°C NEMA/TYP E 4X, HAZ. LOC.  
 INSTALL PER CD0667  
 DUAL SEAL for Process Temps -40°F to 300°F

**554TF(B)**  
 [All product  $\leq$ 299 PSIS]  
  
 APPROVED  
 INTRINSICALLY SAFE FOR USE IN  
 CLASS I,II,III, DIV. 1, GROUPS A,B,C,D,E,F,G  
 CLASS I, ZONE 0, AEx ia IIC T4, Ta=80°C,  
 T5, Ta=40°C NEMA/TYP E 4X, HAZ. LOC.  
 INSTALL PER CD0667

**554TF(C)**  
 [All alternate electrical connections]  
  
 APPROVED  
 INTRINSICALLY SAFE FOR USE IN  
 CLASS I, DIV. 1, GROUPS A,B,C,D,  
 CLASS I, ZONE 0, AEx ia IIC T4, Ta=80°C,  
 T5, Ta=40°C HAZARDOUS LOCATIONS  
 INSTALL PER CD0667

**554NK**  
  
 Ex ia IIC T4 Ga  
 (-20°C < Ta < 40°C)  
 Ui=28V, Ii=100mA, Pi<1W  
 Ci=6,0nF, Li=1,2uH  
 LCIE 03 ATEX 6373 X  
 0575

**554NZ(A)**  
 [All product  $\geq$ 300 PSIS]  
  
 APPROVED  
 NONINCENDIVE FOR USE IN  
 CLASS I, II & III, DIV. 2,  
 GRPS A,B,C,D,F,G  
 CL I, ZN 2, GRP IIC  
 T4, Ta=80°C, T5, Ta=40°C  
 NEMA/TYP E 4X, HAZ LOC  
 DUAL SEAL  
 for Process Temps -40°F to 300°F

**554NZ(B)**  
 [All product  $\leq$ 299 PSIS]  
  
 APPROVED  
 NONINCENDIVE FOR USE IN  
 CLASS I, II & III, DIV. 2,  
 GRPS A,B,C,D,F,G  
 CL I, ZN 2, GRP IIC  
 T4, Ta=80°C, T5, Ta=40°C  
 NEMA/TYP E 4X, HAZ LOC

**554NZ(C)**  
 [ZU option only]  
  
 APPROVED  
 NONINCENDIVE FOR USE IN  
 CLASS I, DIV. 2, GRPS A,B,C,D  
 CL I, ZN 2, GRP IIC  
 T4, Ta=80°C, T5, Ta=40°C HAZ LOC

## SPECIAL CONDITIONS FOR USE

Certificate	Type	Special Instruction
LCIE 03 ATEX 6373 X-03	ATEX Intrinsically Safe	The equipment must only be connected to certified intrinsically safe equipment. This combination must be compatible as regards intrinsic safety use

38 Forge Parkway  
 Franklin, MA 02038  
 Toll Free: 1-800-688-0030  
 International: 716-629-3800  
 Fax: 716-693-9162  
[www.viatran.com](http://www.viatran.com)  
[solutions@viatran.com](mailto:solutions@viatran.com)