



INSTALLATION DATA MANUAL
MODEL 572
PRESSURE TRANSMITTER

38 Forge Parkway
Franklin, MA 02038
Int'l: 1-716-629-3800
Toll Free: 1-800-688-0030
Fax: 1-716-693-9162
www.viatran.com
solutions@viatran.com

PRODUCT OVERVIEW

The products covered by this manual include only those which allow the end user to adjust and reset the transmitter by way of the magnetic control module. Each product is calibrated and tested at the factory for optimum performance to specification prior to shipment. Specific information is needed by model, it will be listed on the attached installation data sheet included with this manual.

Remove and retain all instruction manuals and performance certificates that are shipped with the product. These documents provide important information on the product's calibration, operation, safety precautions, recommended maintenance, re-calibration requirements, repair service instructions and warranty information. These documents are updated from time to time as changes to the product occur and should be reviewed at receipt so that proper and safe installation can occur.

GENERAL REQUIREMENTS & CAUTIONS

Note: This is only a partial list. Please refer to the attached data sheet for requirements by individual model.

1. Installation should occur only after electrical (input power) and line pressure is verified as being off and at zero.
2. The product's internal electrical circuitry is isolated from case ground. It is not recommended that the case or ground of the unit be connected to the input or output of the product or wiring system. Ground loops and line noise will affect the product's performance and may cause internal electrical failure.
3. All products should be protected from direct or continued exposure to fluids at the electrical connection. As an accessory, Viatran offers a NEMA 4X polyhead conduit connection box. If the user experiences a high degree of condensation in his conduit system, a small hole should be drilled in the bottom of the connection box to allow for drainage.
4. At no time should an object be inserted into the pressure port or pressed against the sensing area to deflect the sensor (to test or simulate pressure) as on some models permanent fill loss and/or damage to the sensing diaphragm may occur.
5. During installation it is recommended that the unit be mounted to allow fluids or contamination to flow away from the module screw area, so as not to collect on the screw heads or sockets. (Do not mount the unit facing up.)

BASIC OPERATION & INTERNAL CALIBRATION CIRCUIT

(See Maintenance and Repair for calibration frequency recommendations.)
(Not available on the Model 584, unless NW option is included in the Part Number)

Note: *The casting of the module has raised numbers at the adjustment screw positions. Those numbers reflect the following function of the assigned screw.*

Screw 1: Top Left, Coarse Zero Pot (CCW - Lower, CW - Raise)

Screw 2: Top Right, Fine Zero Pot (CCW - Lower, CW - Raise) – Not available on the Model 584

Screw 3: Lower Left, Internal Cal. Activation Pot (12 or 6 o'clock position – Disengage;
3 o'clock position - Engage) -Model 584 NW Option only

Screw 4: Lower Right, Span Adjustment Pot (CCW - Lower, CW - Raise)

1. Outside of using the calibration circuit or the availability of a metrology lab for obtaining a pressure (Full Scale) reading, no object should be used to physically move the sensor. In the case of the Model 353 and 359, the diaphragm can easily be ruptured by a fingernail.
2. Once proper connections and power are applied, the unit should begin to function.
3. Check the zero (4.00 mA) with the performance certificate to verify condition. If it is out of specification from the performance certificate, use the coarse and fine zero adjustment (not available on the Model 584) screws to obtain the proper reading.
4. With *no* pressure applied, engage the calibration circuit by slowly rotating the calibration screw until the current output rises to about 8.80 mA's (for a standard calibrated range). Check the reading with the performance certificate. If the reading is off, adjust the span screw to raise or lower the reading – return the calibration circuit to the original position.
5. When making zero and/or span adjustments, there may be some interaction between the zero and span readings - repeat adjustments if needed.
6. Always return the calibration screw to off or full CCW position before installing the transmitter into the application.
Note: This is a common reason for incorrect readings at start-up. The calibration circuit must be deactivated in order for the product to perform properly.
7. Once the product has been tested and functionality verified, the power and meter connections may be removed and the product reconnected to the instrumentation loop.

NON-STANDARD RANGE (NSR) CALIBRATION

Definition NSR: *A non-standard range is a customer request to provide alternate scaled readings. Through the use of a single transmitter, numerous pressure ranges can be monitored. Depending upon the model, the transmitter can be scaled down to any pressure range, from three times to five times the original range. Only NSR requests for ranges less than the sensor rated range are recommended and in most cases possible. The module type products have the ability to be re-ranged for different levels of measure. The NSR is possible due to the ability of the adjustment screws to alter*

where the zero and span will fall. Refer to the below example for field NSR calibration.

NSR EXAMPLE

You have Viatran's Model 572 with a standard range of 0 to 300 PSI. You would like to set an NSR of 0 to 150 PSI. Refer to the Performance Certificate and obtain the following:

Zero = 0 PSI = 4.00 mA Full Scale = 300 PSI = 20.00 mA Cal Value = 90.04 PSI = 8.81 mA

In order to recalibrate the transmitter, you must determine the cal reading in mA's at the NSR range. This is done by calculating what the cal output should be at the NSR range. For the example listed, the standard calibration value is set to represent 90.04 PSI. Once internally set, the calibration (Cal) will always represent this pressure.

Use the formula: Cal mA's = [(16 x Standard Cal Pressure) / desired range] + 4

Substitute Actual Numbers: Cal mA's = [(16 x 90.04) / 150] + 4
 Cal mA's = (1440.64 / 150) + 4
 Cal mA's = 9.604 + 4
 Cal mA's = 13.604 mA's

The zero would be set for 4.00 mA's, and the calibration circuit will read (after adjusting span) 13.604 mA's when activated. This would provide a new NSR range for the unit of 4-20 mA's over 0-150 PSI.

PREVENTATIVE MAINTENANCE

Note: This checklist should be followed each time a transmitter requires preventative maintenance. Depending on product usage cycle, all maintenance should be done on a schedule that is reflective of the application.

1. A soft, lint-free, cloth dampened with a process recommended cleaner may be used to clean the sensor to remove excessive media buildup. Never use compounds or solvents that are not compatible with the wetted materials. The sensor area should never be scrubbed with a stiff or metal brush.
2. The sensor surface and/or gasket seal should be visually checked whenever the unit is removed or every 6 months (usage dependent). Any visible damage, especially deep gouges or cuts in the sensor, would require the unit to be returned to Viatran for evaluation.
3. Care should be used when handling the unit by the connection wires. Continued movement of these wires will weaken the seal. Seal failure will result in internal contamination and non-warranty product failure. Visually inspect the connection area every 6 months (usage dependent).
4. The module door should always remain (closed) over the adjustment screws. Constant exposure of the adjustment screws to mists, dusts or contaminants could cause them to become "frozen" in place, causing the module to become locked and non-usable. This would render external adjustment difficult at best. Replacement magnets are available if this problem occurs. Hence a visual inspection of the calibration pots should take place on a 2 to 4 week schedule, or when extreme environmental conditions require it.
5. **NEVER** - Strike a presumed failed transmitter. If the transmitter is in working order, the shock could (and usually does) cause additional failure.
NEVER - Remove a transmitter from an instrumentation loop with the power on. Protection circuitry designed to absorb small power surges could become shorted and cause transmitter failure due to "arcing".
NEVER - Ground a transmitter to AC Return (White). Instant "fatal" failure occurs.
NEVER - Apply input power to the case ground (Green wire). Reduced life span of protection components will occur.

INSTALLATION DATA MANUAL

*NOTE: All information contained in this document is representative of a **standard** Model 572. If the product you ordered has special requirements or modifications, refer to the Laser Marked information on the product and your purchase order for possible alteration to the product's configuration. Failure to verify product configuration before installation may cause permanent product damage and in most cases, void the manufacturer's product warranty. If you are unsure or have questions about your product, please contact our Application Engineers for assistance.*

Output: 4 to 20 mA

Pressure Connection by Range:

100 - 7.5K 1/4" NPT Female

10K - 20K AE type F250-C

Sensor Construction: Bonded Foil Strain Gage

Wetted parts: Hastelloy C-276

Electrical Mating Connection: .

Acceptable 18AWG wire termination conn.

INSTALLATION REQUIREMENTS AND CAUTIONS

1. All electrical and pressure connections should be compatible with the above specifications.
2. When installing the unit to a pressure or electrical connection, only use the wrench flats closest to the end being installed. If the unit is being installed on a pressure pipe, only use the 1 1/4" wrench flats at the end where the pressure port is located, not the 1 1/8" flats at the electrical end.
3. When shipped in quantities, units should be packaged individually to eliminate possible damage.
4. To preserve the integrity of the hermetic design, the units have no field replaceable or repairable parts.

ACCESSORIES - OPTIONAL EQUIPMENT

NEMA 4X Polypropylene Conduit Connection Box	10000PT-25
NEMA 4X Polypropylene Connection Box with 8 Ft. Cable	003667.003
Polypropylene Mounting Bracket (Surface Mount)	004102.013
Stainless Steel Mounting Bracket (Surface Mount)	004016.002
Digital Indicator (Panel Mount)	Consult Factory
Direct Mount Indicator	Consult Factory

<p>572NG</p>  <p>Ex d IIC T6...T4 Gb T6...T4: -20°C<Ta<60°C</p> <p>PRESAFE 16 ATEX 8250X</p> 	<p>572NY</p>  <p>APPROVED EXPLOSION PROOF FOR USE IN CLASS I, DIV. 1, GROUPS A,B,C,D CLASS II/III, DIV. 1, GROUPS E,F,G CLASS I, ZONE 1, AEx d IIC T5 at Ta=88°C NEMA 4X HAZARDOUS LOCATIONS Factory Sealed, Conduit Seal not Required DUAL SEAL for Process Temps -40°F to 300°F</p>	<p>572NZ(A) [All product except ZU]</p>  <p>APPROVED NONINCENDIVE FOR USE IN CLASS I, II & III, DIV. 2, GRPS A,B,C,D,F,G CL I, ZN 2, GRP IIC T4, Ta=80°C, T5, Ta=40°C NEMA/TYP E 4X, HAZ LOC DUAL SEAL for Process Temps -40°F to 300°F</p>	<p>572NZ(B) [ZU option only]</p>  <p>APPROVED NONINCENDIVE FOR USE IN CLASS I, DIV. 2, GRPS A,B,C,D CL I, ZN 2, GRP IIC T4, Ta=80°C, T5, Ta=40°C HAZ LOC</p>
<p>572TF(A) [All product except as noted in labels 572TF(B-D)]</p>  <p>APPROVED INTRINSICALLY SAFE FOR USE IN CLASS I,II,III, DIV. 1, GROUPS A,B,C,D,E,F,G CLASS I, ZONE 0, AEx ia IIC T4, Ta=80°C, T5, Ta=40°C NEMA/TYP E 4X, HAZ. LOC. INSTALL PER CD0633 DUAL SEAL for Process Temps -40°F to 300°F</p>	<p>572TF(B) [*G* Gage format and/or TB option]</p>  <p>APPROVED INTRINSICALLY SAFE FOR USE IN CLASS I, DIV. 1, GROUPS A,B,C,D, CLASS I, ZONE 0, AEx ia IIC T4, Ta=80°C, T5, Ta=40°C HAZARDOUS LOCATIONS INSTALL PER CD0633 DUAL SEAL for Process Temps -40°F to 300°F</p>	<p>572TF(C) [All product ≤299 PSIA/S]</p>  <p>APPROVED INTRINSICALLY SAFE FOR USE IN CLASS I,II,III, DIV. 1, GROUPS A,B,C,D,E,F,G CLASS I, ZONE 0, AEx ia IIC T4, Ta=80°C, T5, Ta=40°C NEMA/TYP E 4X, HAZ. LOC. INSTALL PER CD0633</p>	<p>572TF(D) [All alternate electrical connections]</p>  <p>APPROVED INTRINSICALLY SAFE FOR USE IN CLASS I, DIV. 1, GROUPS A,B,C,D, CLASS I, ZONE 0, AEx ia IIC T4, Ta=80°C, T5, Ta=40°C HAZARDOUS LOCATIONS INSTALL PER CD0633</p>

SPECIAL CONDITIONS FOR USE

Certificate	Type	Special Instruction
Presafe 16 ATEX 8250X	ATEX Flameproof	The pressure transmitters are constructed with permanently connected unterminated conductors and unprotected bushing. The external part of the bushing and the conductors terminated outside the flameproof enclosure shall be protected with one of the types of protection listed in EN 60079-0.
LCIE 03 ATEX 6373 X/03	ATEX Intrinsically Safe	The equipment must only be connected to certified intrinsically safe equipment. This combination must be compatible as regards intrinsic safety use
1000784 (LR 34272)	CSA Intrinsically Safe	Connect per installation drawing. Transmitter must be powered by an approved SELV source, in accordance with CSA standard C22.2 No.1010.1, Annex H

INSTALLATION DATA - VIATRAN MODEL 572

Note: The drawing below is for informational purposes only and is not to scale.
All dimensions are nominal, in inches and for reference purposes only.

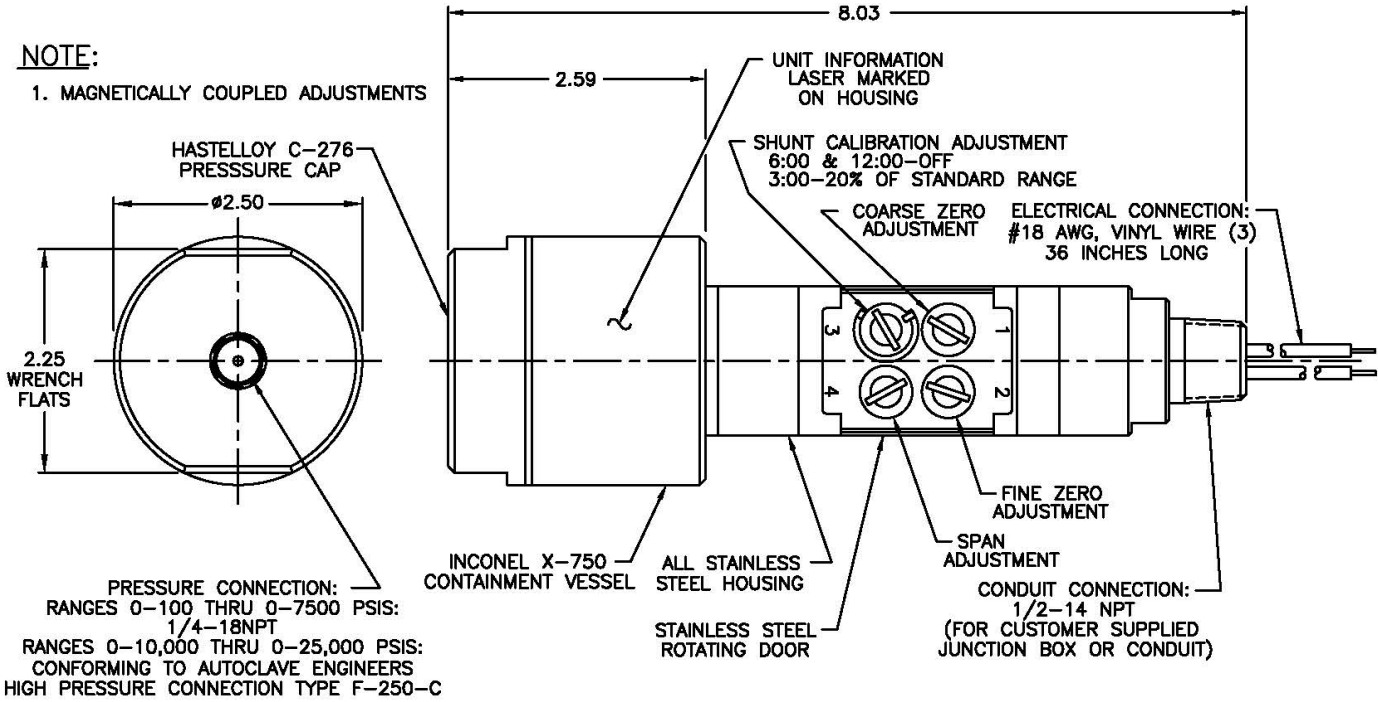

CONNECTION DIAGRAMS & WIRING

Red: + Signal
 Black: - Signal
 Green: Case Ground

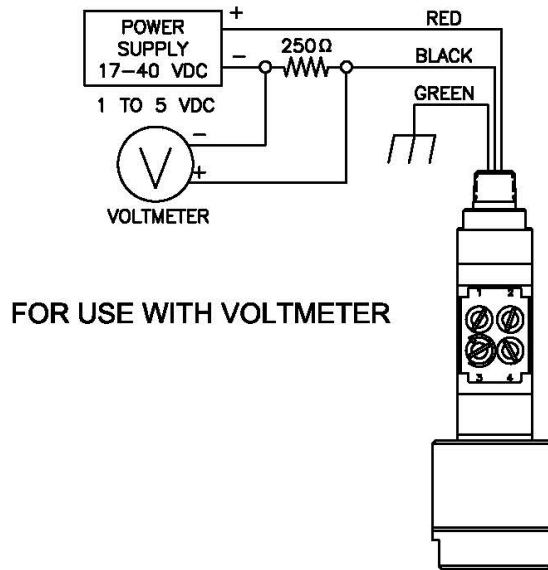
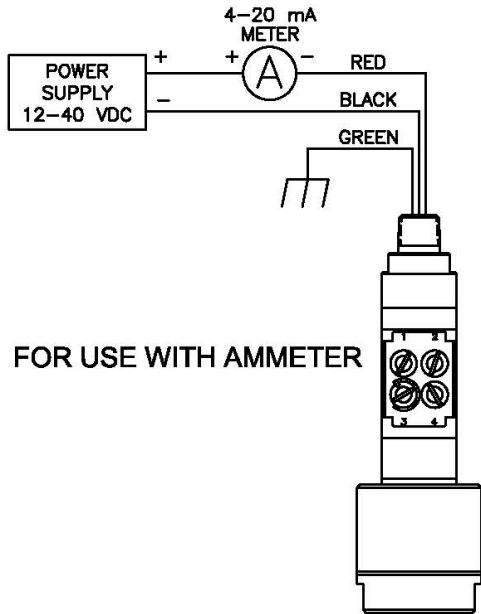

Note: If the unit is certified for hazardous locations as Intrinsically Safe, use the enclosed connection diagram.

MAINTENANCE AND REPAIR

All Viatran transmitters have been designed to function free from routine or scheduled maintenance. Simple cleaning of the electrical connector, pressure port threads and pressure cavity on an as needed basis will provide many years of satisfactory performance. Generally any time the product is removed from service the connector and pressure port threads should be cleaned and the pressure cavity flushed with a wetted materials compatible cleaner to prevent media buildup.

It is suggested that the calibration be verified on a usage dependent schedule. If the product is in continuous service 7 days a week, then calibration verification may be necessary every 6 to 8 months. If the product is in a lab test environment, a more lenient verification schedule would be appropriate. In all instances the performance of the product will depend on the individual application or process where it is installed. More continued usage would require a shorter period between calibration verification and product maintenance.

If a product is perceived to be exhibiting problems, it can be returned to Viatran for analysis and/or repair. It is suggested that only Viatran personnel attempt repair of the product. Any damage resulting from customer disassembly would result in a loss of coverage under the warranty policy. All Viatran products can be repaired at minimal cost if simple cleaning and precautions are taken in the handling and application of the product. Older products returned for repair at times are updated to current specifications unless the repair cost would outweigh the cost of a new replacement model. Products returned for repair should include information on the person to contact for repair quote approval, the individual to contact if Viatran's technical staff requires additional information during analysis and a brief description of the problem associated with the product's failure.

WARRANTY

Viatran Corporation warrants that its products shall be free from defective workmanship and/or material for a period of twelve (12) months from the date of shipment, provided that Viatran's obligation hereunder shall be limited to correcting any defective workmanship and/or replacing any defective material f.o.b. factory. No allowance will be made for any expense incurred for correcting any defective workmanship and/or material without written consent by Viatran. This warranty is in lieu of all other warranties expressed or implied.

REPAIR INSTRUCTIONS

Viatran's Transmitters are designed to be easily repaired and recalibrated if necessary. If a failure occurs, the transmitter should be returned to the factory for inspection and testing. Please contact the Customer Support Department at 1-800-688-0030, for a return tracking number and/or a repair cost estimate. A nominal inspection fee is charged on all units returned to the factory, which are not subsequently repaired or replaced.

CALIBRATION SERVICES

If your facility does not have the capability to perform scheduled calibration verification of the product, Viatran can provide you this service for a nominal fee. Our Customer Support Department will also provide a calibration certificate that meets the intent of ISO 9000 for each product returned for calibration verification. The product must be fully functional and not require repair, outside of normal reset. A calibration tracking number is required prior to returning the product for this service. For more information about this service call the Customer Support Department.

**38 Forge Parkway
Franklin, MA 02038
Int'l: 1-716-629-3800
Toll Free: 1-800-688-0030
Fax: 1-716-693-9162
www.viatran.com
solutions@viatran.com**