



**INSTALLATION DATA MANUAL**  
**MODELS 246 & 346**  
**PRESSURE TRANSMITTER**

**38 Forge Parkway**  
**Franklin, MA 02038**  
**Int'l: 1-716-629-3800**  
**Toll Free: 1-800-688-0030**  
**Fax: 1-716-693-9162**  
**www.viatran.com**  
**[solutions@viatran.com](mailto:solutions@viatran.com)**

## PRODUCT OVERVIEW

NOTE: All information contained in this document is representative of a standard Model 246/346. If the product you ordered has special requirements or modifications, refer to the permanently marked information on the product and your purchase order for possible alteration to the product's configuration. Failure to verify product configuration before installation may cause permanent product damage and in most cases, void the manufacturer's product warranty. If you are unsure or have questions about your product, please contact our Application Engineers for assistance.

Remove and retain all instruction manuals and performance certificates that are shipped with the product. These documents provide important information on the product's calibration, operation, safety precautions, recommended maintenance, re-calibration requirements, repair service instructions and warranty information. These documents are updated from time to time as changes to the product occur and should be reviewed at receipt so that proper and safe installation can occur.

## INSTALLATION DATA - VIATRAN MODEL 246/346

Note: The drawing below is for informational purposes only and is not to scale.

All dimensions are nominal, in inches and for reference purposes only.

Connector:  
PT02E-10-6P

Input:  
9-40 VDC

Output:  
Model 246: 0-5 VDC  
Model 346: 4-20 mA

Sensor Construction  
Bonded Foil Strain Gage

Wetted Parts:  
316 SS and Viton® O-Ring

Pressure Connection:  
1/4" NPT Female

Electrical Mating Connection:  
PT06E-10-6S or Equal

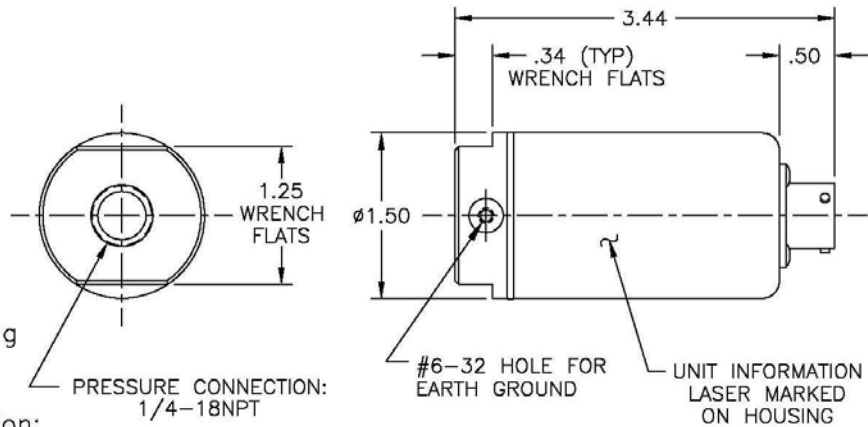

## CONNECTION DIAGRAMS

### MODEL 246

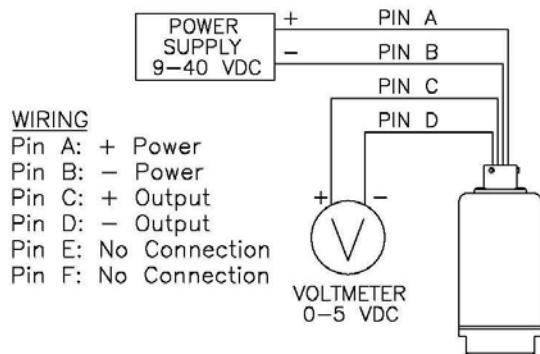

### MODEL 346

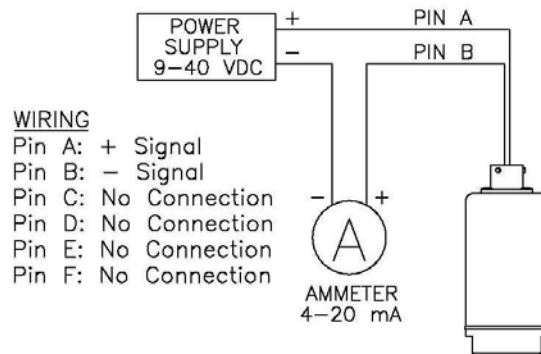

## INSTALLATION REQUIREMENTS & CAUTIONS

Note: This is only a partial list. Please refer to the attached data sheet for requirements by individual model.

1. All electrical & pressure connections should be compatible with the model specifications as outlined in the product installation data sheet.
2. Installation should occur only after electrical (input power) and line pressure is verified as being off and at zero.
3. The product's internal electrical circuitry is isolated from case ground. It is not recommended that the case or ground of the unit be connected to the input, output or calibrate pins of the product or wiring system. Ground loops and line noise will affect the product's performance and will in most cases cause internal electrical failure.
4. All products should be protected from direct or continued exposure to fluids at the electrical connection. It is recommended that for products installed in areas where the potential for contamination at the electrical connection is possible a "boot" or other protective measure be taken to eliminate possible deterioration of the product's electrical connection and corrosion that will impede product performance.
5. On some lower range models a breather opening, with breather plug, is used to allow for proper product function. At no time should any mist, vapor or fluid be permitted to enter this breather as total unit failure will occur. (A protective boot may be required.)
6. At no time should an object be inserted into the pressure port or pressed against the sensing area to deflect the sensor (to test or simulate pressure), as on some models permanent damage to the sensing diaphragm may occur.
7. NEVER - Strike a presumed failed transmitter. If the transmitter is in working order, the shock could cause additional failure.
8. NEVER - Remove a transmitter from an instrumentation loop with the power on. Protection circuitry designed to absorb small power surges could become shorted and cause transmitter failure due to "arcing".
9. NEVER - Ground a transmitter to AC Return (Black). Instant "fatal" failure occurs.
10. NEVER - Apply input power to the case ground (Green wire). Reduced life span of protection components will occur.

## BASIC OPERATION

The Models 246 and 346 have been pre-set at the factory for the required output. Once factory set, the product should perform as indicated by the performance certificate and product labeling. In all cases the zero and span cannot be externally adjusted, hence any deviation from the factory settings would indicate damage to the sensor, electronics (model dependent), or both. For absolutes, the pressure port must have a full vacuum applied to reach the absolute zero point. After the full vacuum is applied, the unit will begin to read positive pressure changes as less and less of a vacuum is evident at the pressure port.

## ACCESSORIES - OPTIONAL EQUIPMENT

Mounting Bracket	004080.012
Mating Electrical Connector	10MSPT1106
Mating Electrical Cable Assembly	230002.002
Mating Electrical Cable Assembly (Improved Shielding)	230043.012
Digital Meter	Consult Factory

## MAINTENANCE AND REPAIR

All Viatran transmitters have been designed to function free from routine or scheduled maintenance. Simple cleaning of the electrical connector, pressure port threads and pressure cavity on an as needed basis will provide many years of satisfactory performance. Protecting the product from continued exposure to moisture or fluids at the electrical connection, breather area (model dependent) will eliminate premature internal failure of the product. Generally any time the product is removed from service the connector and pressure port threads should be cleaned and the pressure cavity flushed with a 316SS and/or O-Ring (material model/option dependent) compatible cleaner to prevent media buildup. During the cleaning process only a soft, lint-free cloth is recommended. Never use a coarse or stiff bristle brush to clean media from the diaphragm surface.

It is suggested that the calibration be verified on a usage dependent schedule. If the product is in continuous service 7 days a week, then calibration verification may be necessary every 6 to 8 months. If the product is in a lab test environment a more lenient verification schedule would be appropriate. In all instances the performance of the product will depend on the individual application or process in which it is installed. More continued usage would require a shorter period between calibration verification and product maintenance.

If a product is perceived to be exhibiting problems, it can be returned to Viatran for analysis and/or repair. It is suggested that only Viatran personnel attempt repair of the product. Any damage resulting from customer disassembly would result in a loss of coverage under the warranty policy. All Viatran products are able to be repaired at minimal cost if simple cleaning and precautions are taken in the handling and application of the product. Older products returned for repair are updated to current specifications unless the repair cost would outweigh the cost of a new replacement model. Products returned for repair should include information on the person to contact for repair quote approval, the individual to contact if Viatran's technical staff requires additional information during analysis, and a brief description of the problem associated with the product's failure.

## WARRANTY

Viatran Corporation warrants that its products shall be free from defective workmanship and/or material for a period of twelve (12) months from the date of shipment, provided that Viatran's obligation hereunder shall be limited to correcting any defective workmanship and/or replacing any defective material f.o.b. factory. No allowance will be made for any expense incurred for correcting any defective workmanship and/or material without written consent by Viatran. This warranty is in lieu of all other warranties expressed or implied.

## REPAIR INSTRUCTIONS

Viatran's Transmitters are designed to be easily repaired and recalibrated if necessary. If a failure occurs, the transmitter should be returned to the factory for inspection and testing. Please contact the Customer Support Department at 1-800-688-0030, for a return tracking number and/or a repair cost estimate. A nominal inspection fee is charged on all units returned to the factory which are not subsequently repaired.

**38 Forge Parkway  
Franklin, MA 02038  
Int'l: 1-716-629-3800  
Toll Free: 1-800-688-0030  
Fax: 1-716-693-9162  
www.viatran.com  
[solutions@viatran.com](mailto:solutions@viatran.com)**