



INSTALLATION DATA MANUAL
MODEL 240
PRESSURE TRANSMITTER

**199 Fire Tower Drive
Tonawanda, NY 14150
Int'l: 1-716-629-3800
Toll Free: 1-800-688-0030
Fax: 1-716-693-9162
www.viatran.com
solutions@viatran.com**

PRODUCT OVERVIEW

All information contained in this document is representative of a standard Model 240. If the product you ordered has special requirements or modifications, refer to the information marked on the product and your purchase order for possible alteration to the product's configuration. Failure to verify product configuration before installation may cause permanent product damage and in most cases, void the manufacturer's product warranty. If you are unsure or have questions about your product, please contact our Application Engineers for assistance. Remove and retain all instruction manuals and performance certificates that are shipped with the product. These documents provide important information on the product's calibration, operation, safety precautions, recommended maintenance, recalibration requirements, repair service instructions and warranty information. These documents are updated from time to time as changes to the product occur and should be reviewed at receipt so that proper and safe installation can occur.

GENERAL REQUIREMENTS & CAUTIONS

1. All electrical & pressure connections should be compatible with the model specifications as outlined below.
2. Installation should occur only after electrical (input power) and line pressure is verified as being off and at zero.
3. The 240 is susceptible to sensor damage by being dropped, struck, or installed in a high vibration environment.
4. The product's internal electrical circuitry is isolated from case ground. The case or ground of the unit should not be connected to the input, output or calibrate pins of the product or wiring system. Ground loops and line noise will affect the product's performance and will in most cases cause internal electrical failure. The transducer housing should never have power applied to it.
5. All products should be protected from direct or continued exposure to fluids at the electrical connection. It is recommended that for products installed in areas where the potential for contamination at the electrical connection is possible a "boot" or other protective measure be taken to eliminate possible deterioration of the product's electrical connection and corrosion that will impede product performance.
6. On some lower range models a breather opening, with breather plug, is used to allow for proper product function. At no time should any mist, vapor or fluid be permitted to enter this breather as unit failure may occur. (A protective cover may be required.)
7. At no time should an object be inserted into the pressure port or pressed against the sensing area to deflect the sensor (to test or simulate pressure), as on some models permanent damage to the sensing diaphragm may occur.
8. Never exert excessive inward force on the adjustment screw, as the potentiometer could break away from the electronics and cause immediate or partial electronic failure.
9. When shipped in quantities, units should be packaged individually to eliminate possible damage.
10. The model 340 is CE compliant. The CE circuitry requires the transducer housing to be grounded. Power should never be applied to the housing.

BASIC OPERATION

The "40" Series has been pre-set at the factory for the required output. Typical output is 0-5 VDC. With the exception of absolute units which are referenced to absolute zero (full vacuum), all other products are referenced to atmospheric pressure (zero PSIG). Once factory set, the product should perform as indicated by the performance certificate and product labeling. In all cases the zero and span cannot be externally adjusted, hence any deviation from the factory settings could indicate damage to the sensor, electronics (model dependent), or both.

- A. For compound ranges, (a negative pressure to a positive pressure, i.e. -15 to +15), the zero balance will occur and be set for zero PSIG. For the compound range the output of the transmitter will be evenly and proportionately split between the plus and minus pressure ranges with respect to zero. The output would be plus or minus depending on the type of pressure applied to the pressure port.
- B. Output for gage and sealed units will go positive with positive pressure applied to the pressure port.
- C. With vacuum units, the output will go positive with increased vacuum at its pressure port.
- D. For absolutes, the pressure port must have a full vacuum applied to reach the absolute zero point. After the full vacuum is applied, the unit will begin to read positive pressure changes as less and less of a vacuum is evident at the pressure port.

CALIBRATION CIRCUIT

An internal calibration circuit is optionally available on the Model 240. This feature provides the user a confirmation that the unit is still in calibration. This is especially useful when a standardized pressure source is not available. The operation has the user short two conductors, which will electronically simulate an 80% pressure being applied to the instrument. The exact pressure and equivalent signal output for each individual instrument is listed on the product's calibration certificate as are the wires, or pins, used for this feature. This feature is also useful when the transducer's signal will be sent to a readout device, such as a digital meter, and the user requires some known calibration points. Shorting the conductors will provide a known calibration value to the meter allowing for quick setup of the system.

In all cases, the calibration signal is referenced from atmospheric pressure, or zero PSIG, with the exception of absolute products. Absolute products have the calibration signal referenced from a full vacuum, or zero PSIA.

The conductors dedicated to the field calibration circuit should never have power applied to them. Misconnection to any of the product's designated pin assignments will cause internal, instantaneous or delayed product failure.

Note: The calibration circuit must be deactivated in order for the product to perform properly.

ACCESSORIES - OPTIONAL EQUIPMENT

Please contact Viatran for these and other available accessories.

Mating Connectors	Mounting Brackets
Digital Indicators	Protective Cover

INSTALLATION DATA - VIATRAN MODEL 240

Note: The drawing below is for informational purposes only and is not to scale.

All dimensions are nominal, in inches and for reference purposes only.

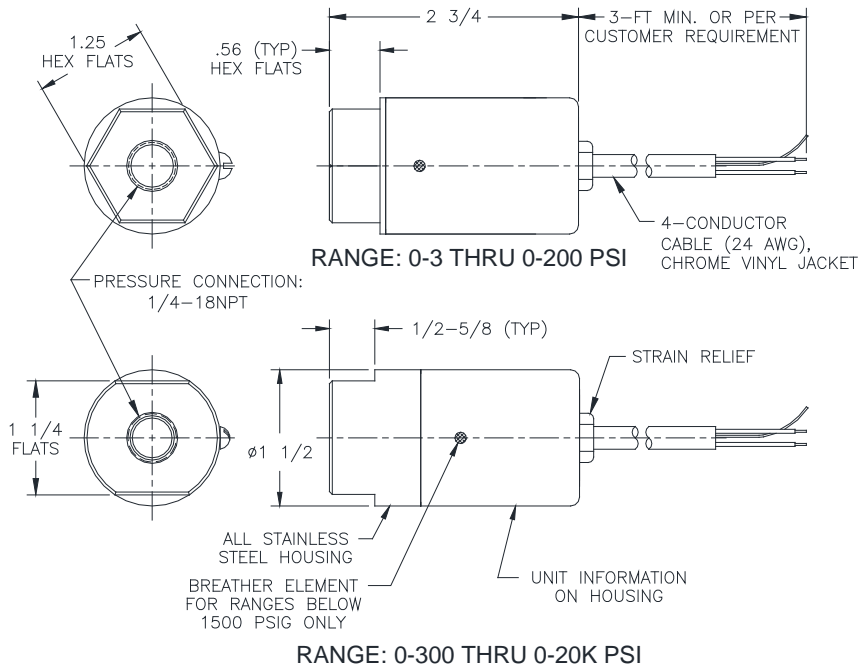

Sensor Construction and Wetted Materials:

0 - 3 thru 0 - 200 PSI: Oil Filled - Silicon - 316 Stainless Steel
 >200 PSI: Bonded Foil Strain Gage - 15-5 PH Stainless Steel

Pressure Connection:

1/4" NPT female

Electrical Mating Connection:

Acceptable 24 AWG Wire Termination Connection

Input:

8 - 30 VDC

Output:

0 - 5 VDC

CONNECTION DIAGRAMS & WIRING

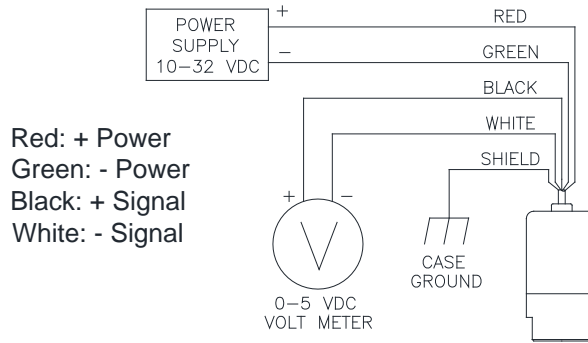

MAINTENANCE AND REPAIR

All Viatran transmitters have been designed to function free from routine or scheduled maintenance. Simple cleaning of the pressure cavity on an as needed basis will provide many years of satisfactory performance. Protecting the product from continued exposure to moisture or fluids at the electrical connection, breather area will eliminate premature internal failure of the product. Generally any time the product is removed from service, the pressure cavity should be flushed with a stainless steel compatible cleaner to prevent media buildup. During the cleaning process only a soft, lint-free cloth is recommended. Never use a coarse or stiff bristle brush to clean media from the diaphragm surface.

It is suggested that the calibration be verified on a usage dependent schedule. If the product is in continuous service 7 days a week, then calibration verification may be necessary every 6 to 8 months. If the product is in a lab test environment, a more lenient verification schedule would be appropriate. In all instances the performance of the product will depend on the individual application or process in which it is installed. More continued usage would require a shorter period between calibration verification and product maintenance.

If a product is perceived to be exhibiting problems, it can be returned to Viatran for analysis and/or repair. It is suggested that only Viatran personnel attempt repair of the product. Any damage resulting from customer disassembly would result in a loss of coverage under the warranty policy. Older products returned for repair are updated to current specifications unless the repair cost would outweigh the cost of a new replacement model. Products returned for repair should include information on the person to contact for repair quote approval, the individual to contact if Viatran's technical staff requires additional information during analysis, and a brief description of the problem associated with the product's failure.

REPAIR INSTRUCTIONS

Viatran's Transmitters are designed to be easily repaired and recalibrated if necessary. If a failure occurs, the transmitter should be returned to the factory for inspection and testing. Please contact the Customer Support Department at 1-800-688-0030, for a return tracking number and/or a repair cost estimate. A nominal inspection fee is charged on all units returned to the factory which are not subsequently repaired.

WARRANTY

Viatran Corporation warrants that its products shall be free from defective workmanship and/or material for a period of twelve (12) months from the date of shipment, provided that Viatran's obligation hereunder shall be limited to correcting any defective workmanship and/or replacing any defective material f.o.b. factory. No allowance will be made for any expense incurred for correcting any defective workmanship and/or material without written consent by Viatran. This warranty is in lieu of all other warranties expressed or implied.

**199 Fire Tower Drive
Tonawanda, NY 14150
Int'l: 1-716-629-3800
Toll Free: 1-800-688-0030
Fax: 1-716-693-9162
www.viatran.com
solutions@viatran.com**