



INSTALLATION DATA MANUAL  
Model 511 Pressure Transmitter



3829 Forest Parkway, Suite 500  
Wheatfield, NY 14120  
Toll Free: 1-800-688-0030  
International: 1-716-629-3800  
Fax: 716-693-9162  
[www.viatran.com](http://www.viatran.com)  
[solutions@viatran.com](mailto:solutions@viatran.com)

## PRODUCT OVERVIEW

*NOTE: All information contained in this document is representative of a standard Model 511. If the product you ordered has special requirements or modifications, refer to the Laser Marked information on the product and your purchase order for possible alteration to the product's configuration. Failure to verify product configuration before installation may cause permanent product damage and in most cases, void the manufacturer's product warranty. If you are unsure or have questions about your product, please contact our Application Engineers for assistance. Remove and retain all instruction manuals and performance certificates that are shipped with the product. These documents provide important information on the product's calibration, operation, safety precautions, recommended maintenance, re-calibration requirements, repair service instructions and warranty information. These documents are updated from time to time as changes to the product occur and should be reviewed at receipt so that proper and safe installation can occur.*

## DESCRIPTION

The Viatran Model 511 is a pressure transmitter designed specifically for oil field service applications. This transmitter provides a 4-20 mA signal output proportional to pressure. The Hammer Union pressure connection and low profile design make it ideal for use at the well site. Please note that this manual, and subsequent details are inclusive for the Viatran Model 512 and 513 pressure transmitters.

## GENERAL REQUIREMENTS & CAUTIONS

*Note: This is only a partial list. Please refer to the Installation Data section of this manual for specific requirements.*

1. All electrical & pressure connections should be compatible with the model specifications as outlined in the Installation Data section of this manual.
2. Installation should occur only after electrical (input power) and line pressure is verified as being off and at zero.
3. The product's internal electrical circuitry is isolated from case ground. It is not recommended that the case or ground of the unit be connected to the input, output or calibrate pins of the product or wiring system. Ground loops and line noise will affect the product's performance and will in most cases cause internal electrical failure.
4. All products should be protected from direct or continued exposure to fluids at the electrical connection. It is recommended that for products installed in areas where the potential for contamination at the electrical connection is possible, protective measures be taken to eliminate possible deterioration of the product's electrical connection and corrosion that will impede product performance.
5. At no time should an object be inserted into the pressure port or pressed against the sensing area to deflect the sensor (to test or simulate pressure), as on some models permanent damage to the sensing diaphragm may occur.
6. Never - Remove the transmitter when it is under pressure, if it is hot, or if it exposes noxious gases.

## HANDLING

Although there are variations within the series of sensors, the nominal weight of the assembly is about 5.5 lbs. This is of significant size and a handle is available to facilitate handling. High surface temperatures can remain in place and the unit should be checked before removing the unit from service if it was operated at high temperatures. Suitable gloves are recommended for handling the unit under those conditions. There are no sharp edges associated with the instrument.

## INSTALLATION REQUIREMENTS & CAUTIONS

1. To comply with CE requirements for electromagnetic compatibility, the transmitter case must be earthed by the ground lug at the connector.
2. It is recommended that the connector cover be placed on the product's connector after each use. Simple cleaning and removal of foreign material in the connector will increase the life and operation of the product.
3. The carrying handle and connector cover should be used when the product is being handled or transported between locations.
4. Installation of the unit is accomplished by placing the pressure transmitter into the Hammer Union pressure fitting and securing the unit by tightening the Hammer Union Nut (Fig. 1) over both the unit and pressure fitting. Once installed, check for leaks and adjust as necessary.



- When installing the unit to the pressure connection, care should be taken to avoid direct hits to the unit. A direct hit from a sledgehammer to the product itself could cause latent failure to the product. Direct hits can result in the loss of retention clips, failure of the electrical connector or electronics, or bending of the top assembly from the body which would allow sensor cavity contamination. In all cases this would be determined as a non-warranty related product failure and repair.

## Installation Data – Viatran

### Model 511 Wiring:

Pin A:	+Signal/Power
Pin B:	- Signal/Power
Pin C:	No Connection
Pin D:	No Connection
Pin E:	+Calibration
Pin F:	- Calibration
Gnd Lug:	Case Ground

To activate cal on Model 511, the cal circuit must be powered.

<b>Input:</b>	9 – 28 VDC
<b>Output:</b>	4 to 20 mA
<b>Cal Input:</b>	8.5 to 28 VDC

### Sensor Construction:

All Ranges: Inconel 718, 17-4PH optional

### Electrical Connector:

6 pin bayonet (standard)

### Pressure Connection by Range:

5,000, 6,000, 10,000, 15,000 & 20,000 PSI: 2" 1502 Hammer Union

## Connection Diagram (Hazardous Environments)

### Note:

If the unit is certified for Hazardous Locations as Intrinsically Safe, use the connection diagram that was enclosed with the unit.

## Connection Diagram (Non Hazardous Environments)

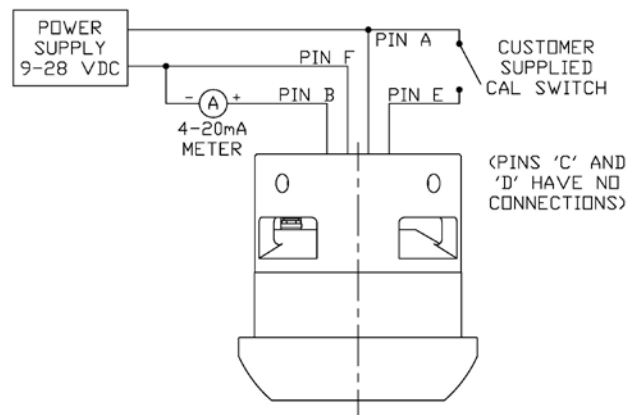

## STANDARD VIATRAN PRODUCT MARKING



3829 FOREST PARKWAY,  
SUITE 500, WHEATFIELD,  
NEW YORK USA  
1-800-688-0030

P/N: 511XXX  
S/N: XXXXXX  
Press. Range: XXXXXX PSIS  
Proof Press: XXXXXX PSIS

Input: 9-28VDC  
Output: 4-20mA  
Mfg. Year: XXXX

CONNECTIONS:  
Pin A: +Sig/Pwr Pin D: N/C  
Pin B: - Sig/Pwr Pin E: +Calibrate  
Pin C: N/C Pin F: - Calibrate













US Patent D 711266  
EU Patent 002334250-001  
CN Patent ZL

## FIELD CALIBRATION

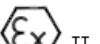
The 511 Transmitter is provided with a unique feature which permits field calibration to be performed by electronically simulating pressure. Powering the calibration terminals produces a signal output equivalent to approximately 100% of full scale pressure. The factory set calibration signal is located on the calibration certificate that is shipped with each unit. This can be used to adjust the gain on the user's meter or data acquisition equipment. The cal signal is also an indication that the unit is working properly. Zero & Full Scale adjust are also featured on the Model 511 and should not be confused with cal activation. Model 511 has a calibration feature built in which requires the use of a HART command, provided either with a handheld device or with pc software and a HART modem. For more information on utilizing this feature, reference Users Manual for Viatran 511 Trim Feature using HART software.

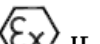
## OPTIONAL CERTIFICATIONS

1. Enclosure Classification: NEMA 6P, IP68 (Standard)
2. Hazardous Locations Classifications/Marking: (Approval option codes specified in part number to obtain appropriate agency labeling.) See the product & connection drawing for any approvals & ratings for your unit, if applicable. The following are typical examples.

<p>511_NX_                    APPROVED                  INT. SAFE FOR                  CL I DIV 1, GP A,B,C,D                  CL I ZN 0, Ex Ia IIC Ga                  T4 Ta = -40°C - 85°C                  T5 Ta = -40°C - 40°C                  INSTALL PER CD0671                  IP68 &amp; TYPE 6P</p>	<p>511_TF_                    APPROVED                  INT. SAFE FOR                  CL I DIV 1, GP A,B,C,D                  CL I ZN 0, AEx Ia IIC                  T4 Ta = -40°C - 85°C                  T5 Ta = -40°C - 40°C                  INSTALL PER CD0671                  IP68 &amp; TYPE 6P</p>	<p>511_NZ_                    APPROVED                  NON-HAZARDOUS FOR USE IN                  CL I DIV 2, GP A,B,C,D                  CL I ZN 2, AEx nA IIC                  T4 Ta = -40°C - 85°C                  T5 Ta = -40°C - 40°C                  IP68 &amp; TYPE 6P</p>	<p>511_TG_                    APPROVED                  INT. SAFE FOR                  CL I DIV 1, GP A,B,C,D                  USA: CL I ZN 0, AEx Ia IIC                  CANADA: CL I ZN 0, Ex Ia IIC                  T4 Ta = -40°C - 85°C                  T5 Ta = -40°C - 40°C                  INSTALL PER CD0671                  IP68 &amp; TYPE 6P</p>		
<p>511_TJ_                    APPROVED                  NON-HAZARDOUS FOR USE IN                  CL I DIV 2, GP A,B,C,D                  CL I ZN 2, Ex nA IIC Gc                  T4 Ta = -40°C - 85°C                  T5 Ta = -40°C - 40°C                  IP68 &amp; TYPE 6P</p>	<p>511_NZTJ_                    APPROVED                  NON-HAZARDOUS FOR USE IN                  CL I DIV 2, GP A,B,C,D                  USA: CL I ZN 2, AEx nA IIC                  CANADA: CL I ZN 2, Ex nA IIC                  T4 Ta = -40°C - 85°C                  T5 Ta = -40°C - 40°C                  IP68 &amp; TYPE 6P</p>	<p>511_NK_(A)                  [Connector or                  W/re/Cable ≤ 1FT]   II 1 G                  Ex Ia IIC Ga                  FM15ATEX0006                  T4 Ta = -40°C - 85°C                  T5 Ta = -40°C - 40°C                  UI=28V, I<sub>I</sub>=100mA, P<sub>I</sub> ≤ 1W                  C<sub>I</sub>=6 nF, L<sub>I</sub>=2.2 μH                  IP68   2460</p>	<p>511_NK_(B)                  [With 1' &lt;                  W/re/Cable ≤ 100']   II 1 G                  Ex Ia IIC Ga                  FM15ATEX0006                  T4 Ta = -40°C - 85°C                  T5 Ta = -40°C - 40°C                  UI=28V, I<sub>I</sub>=100mA, P<sub>I</sub> ≤ 1W                  C<sub>I</sub>=12 nF, L<sub>I</sub>=22.2 μH                  IP68   2460</p>	<p>511_TK_   II 3 G                  Ex nA IIC Gc                  FM15ATEX0062X                  T4 Ta = -40°C - 85°C                  T5 Ta = -40°C - 40°C                  IP68  </p>	<p>511_TW_  </p>
<p>511_KH_(A)                  [Connector]                  IECEx FMG 15.0002                  Ex Ia IIC Ga                  T4 Ta = -40°C - 85°C                  T5 Ta = -40°C - 40°C                  UI=28V, I<sub>I</sub>=100mA, P<sub>I</sub> ≤ 1W                  C<sub>I</sub>=6 nF, L<sub>I</sub>=2.2 μH                  IP68</p>	<p>511_KH_(B)                  [W/re/Cable; ≤ 100']                  IECEx FMG 15.0002                  Ex Ia IIC Ga                  T4 Ta = -40°C - 85°C                  T5 Ta = -40°C - 40°C                  UI=28V, I<sub>I</sub>=100mA, P<sub>I</sub> ≤ 1W                  C<sub>I</sub>=12 nF, L<sub>I</sub>=22.2 μH                  IP68</p>				

## AVAILABLE OPTIONS

- |   |  |
|---|--|
| DC: Compensated Temperature -40°F to 140°F      | NA: Carrying Handle Attached                                   |
| DG: Improved Temperature Compensation           | NH: Customer Specified Identification                          |
| DH: Special Range                               | NP: Protective Ring Cage                                       |
| DN: Improved Accuracy                           | NQ: Protective Criss-Cross Cage                                |
| EA: Special Calibration Run                     | QJ: 17-4 PH Wetted Material, Heat Treated per NACE MR0175-2000 |
| EH: Compensated Temperature Range 40°F to 180°F | Z( ): Special Connectors                                       |

## INTENDED USE AND MISUSE

The standard configuration of this instrument is designed for use with materials compatible with Inconel 718. If fluids that are incompatible are used, accelerated corrosion rates are likely to be seen. This will result in premature failure of the diaphragm.

## MAINTENANCE AND REPAIR

All Viatran transmitters have been designed to function free from routine or scheduled maintenance. Simple cleaning of the electrical connector, pressure port threads and pressure cavity on an as needed basis will provide many years of satisfactory performance. Protecting the product from continued exposure to moisture or fluids at the electrical connection will eliminate premature internal failure of the product. Generally any time the product is removed from service the connector and pressure

port should be cleaned and the pressure cavity flushed with an Inconel 718 compatible cleaner to prevent media buildup. During the cleaning process only a soft, lint-free cloth is recommended. Never use a coarse or stiff bristle brush to clean media from the diaphragm surface.

It is suggested that the calibration be verified on a usage dependent schedule. If the product is in continuous service 7 days a week, then calibration verification may be necessary every 6 to 8 months. If the product is in a lab test environment a more lenient verification schedule would be appropriate. In all instances the performance of the product will depend on the individual application or process in which it is installed. More continued usage would require a shorter period between calibration verification and product maintenance.

If a product is perceived to be exhibiting problems, it can be returned to Viatran for analysis and/or repair. It is suggested that only Viatran personnel attempt repair of the product. Any damage resulting from customer disassembly would result in a loss of coverage under the warranty policy. All Viatran products are able to be repaired at minimal cost if simple cleaning and precautions are taken in the handling and application of the product. Older products returned for repair are updated to current specifications unless the repair cost would outweigh the cost of a new replacement model. Products returned for repair should include information on the person to contact for repair quote approval, the individual to contact if Viatran's technical staff requires additional information during analysis, and a brief description of the problem associated with the product's failure.

## **WARRANTY**

Viatran Corporation products shall be free from defective workmanship and/or material for a period of twelve (12) months from date of shipment, provided that Viatran's obligation hereunder shall be limited to correcting any defective workmanship and/or replacing any defective material F.O.B. destination. If inspection by the Company of such product does not disclose any defect of workmanship or material, the Company's regular charges will apply. The warranty carries no liability, either expressed or implied, beyond our obligation to replace the unit which carries the warranty. This warranty is in lieu of all other warranties of merchantability or fitness. No allowance will be made for any expense incurred for correcting any defective workmanship and/or material without written consent by Viatran. Unit must be shipped to the Company, transportation prepaid, and return tracking number must be referenced on the package to assure acceptance at our shipping dock. Prices, specifications and decisions are subject to change without notice.

This warranty is void if the product is subjected to misuse, accident, neglect improper application, installation or operation. This warranty is void if prior defects in materials or workmanship repairs are made by anyone except Viatran or its authorized service agency.

## **REPAIR**

If failure occurs, the sensor should be returned to the factory for inspection and testing. If the failure is covered by our warranty policy as stated above, the unit will be repaired as necessary and reshipped without delay. Sensors usually not covered by warranty can be repaired within two to three weeks (after approval) for approximately 20-60% of the purchase price. Simple repairs can often be made for a minimal charge. A repair is warranted ninety (90) days from repair date under conditions of original warranty period unless superseded by original warranty period. To return a unit, please contact the Customer Support Department for a Return Tracking Number at 1-800-688-0030.

Viatran Corporation  
3829 Forest Parkway, Suite 500  
Wheatfield, NY 14120